

# 3M™ THREE-WALL HEADER, 3000 SERIES

.100" X .100" LATCH/EJECTOR, STRAIGHT AND RIGHT ANGLE

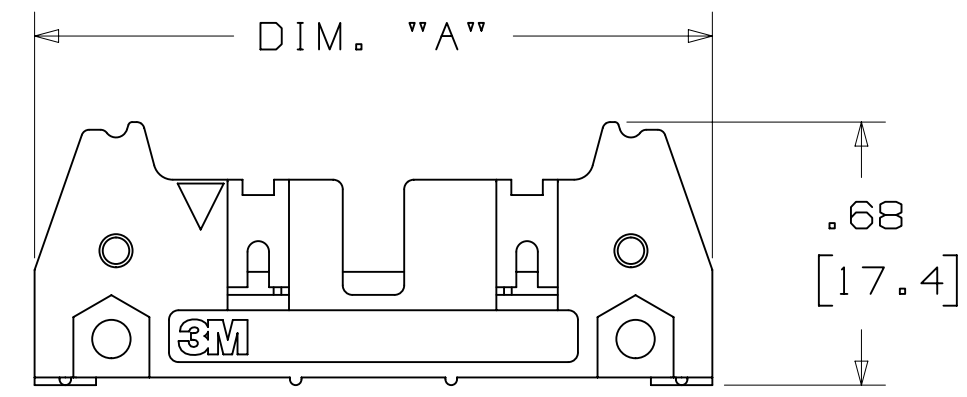

-X0XX  
HEADER WITHOUT LATCH/EJECTOR

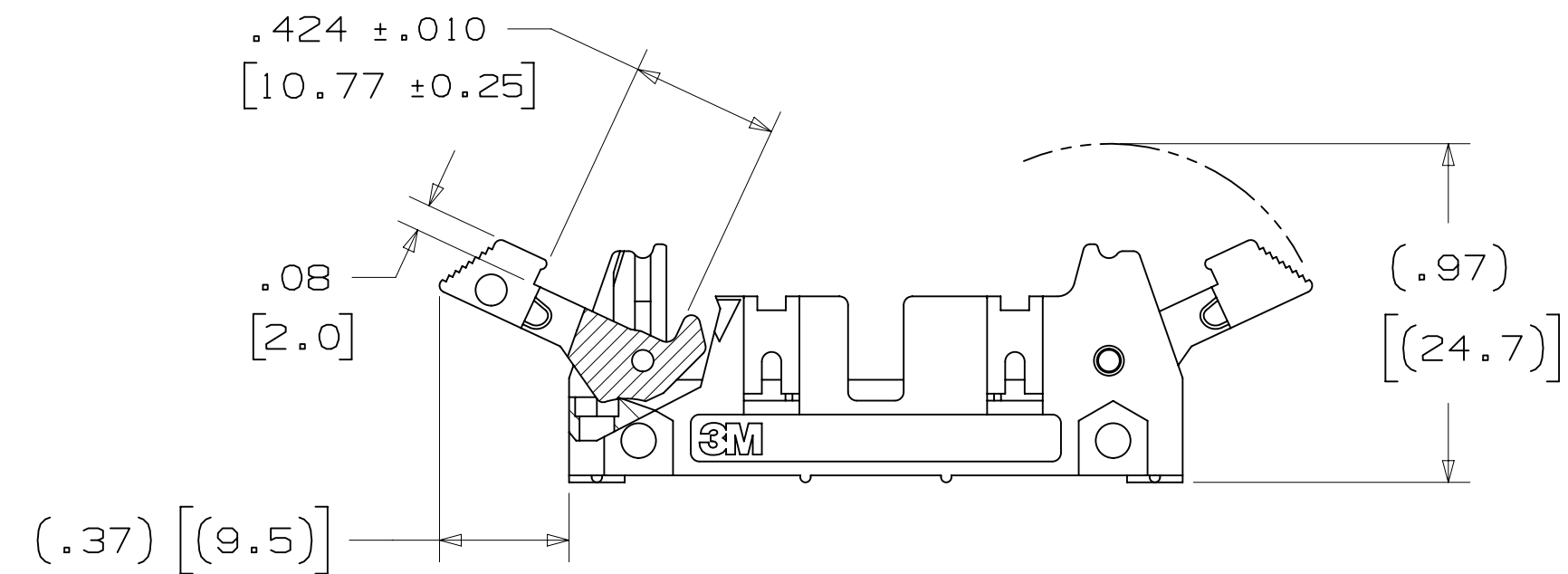

-X2XX  
HEADER WITH SHORT LATCH/EJECTOR  
FOR 3M SOCKETS WITHOUT STRAIN RELIEF

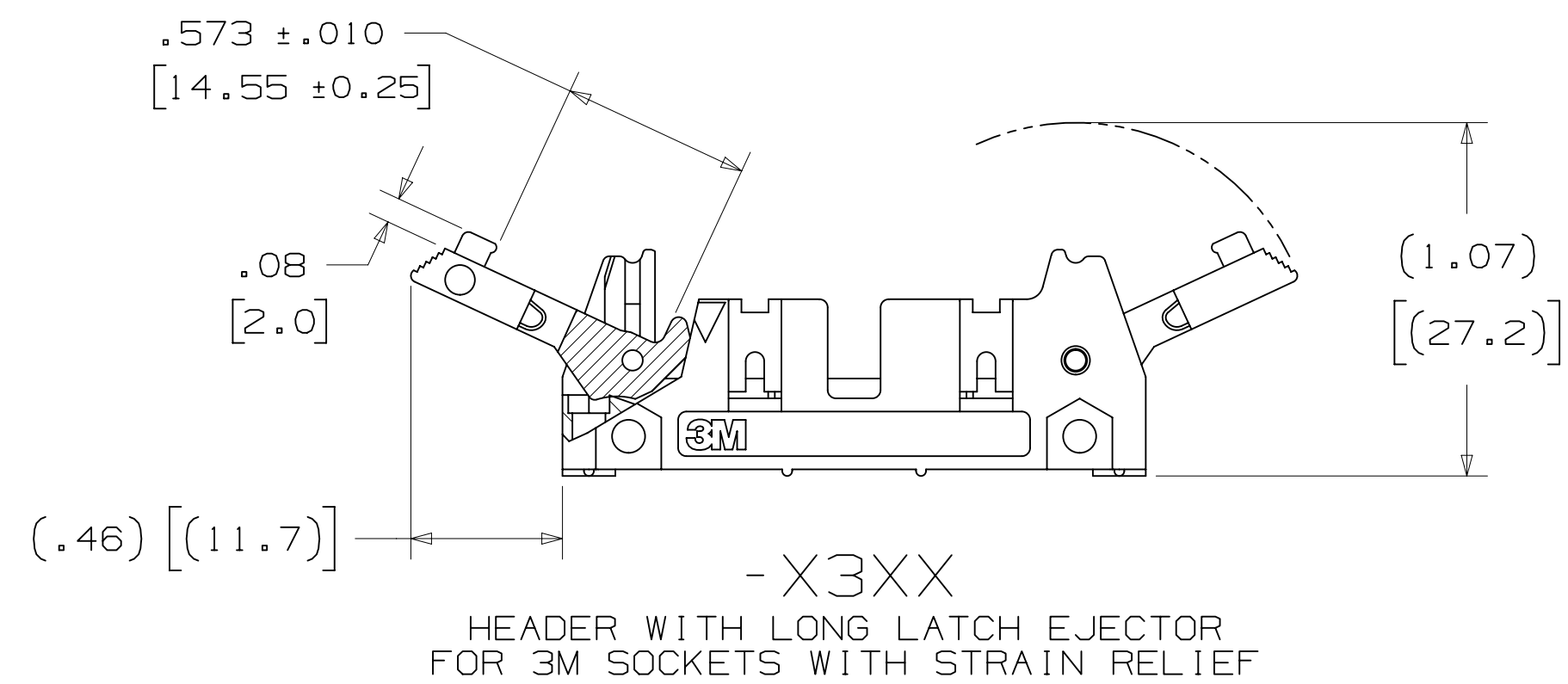

-X3XX  
HEADER WITH LONG LATCH/EJECTOR  
FOR 3M SOCKETS WITH STRAIN RELIEF

- \* MILITARY (WITH 3M'S N3518 POLARIZING KEY) AND CENTERBUMP POLARIZATION.
- \* LOW PROFILE.
- \* OPTIONAL EJECTOR LATCHES.
- \* MOUNTING HOLES FOR SECURING HEADER TO BOARD.
- \* THREE WALL SHROUD PROVIDES DESIGN FLEXIBILITY.
- \* SOLDER TAIL AND WRAP TAIL OPTIONS.
- \* OPTIONAL POLARIZING POSTS AVAILABLE.
- \* HIGH TEMPERATURE INSULATOR SUITABLE FOR "NO LEAD" SOLDERING OPERATIONS.
- \* SUITABLE FOR REFLOW SOLDERING USING "PASTE IN HOLE" TECHNIQUES.

## 2 PHYSICAL :

INSULATOR: GLASS FILLED POLYESTER (PCT)  
 MATERIAL: UL94V-0  
 FLAMMABILITY: UL94V-0  
 COLOR: BLACK  
 CONTACT: COPPER ALLOY  
 PLATING: 100μ" [2.54μm] NICKEL-OVERALL  
 UNDER PLATING: 30μ" [0.76μm] AVG. GOLD  
 WIPING AREA: 200μ" [5.08μm] TIN LEAD OR MATTE TIN (SEE ORDERING INFORMATION)  
 MARKINGS: 3M LOGO, PART IDENTIFICATION NUMBER AND ORIENTATION TRIANGLE

## 2 ELECTRICAL :

CURRENT RATING: 5.00A, 1 CONTACT POWERED  
 3.00A, 6 CONTACTS POWERED  
 1.75A, ALL CONTACTS POWERED  
 RATING CONDITIONS: EIA-364-070 METHOD 2, 30°C MAXIMUM TEMPERATURE RISE, 20% DERATED. REFERENCE APPROPRIATE 3M PRODUCT SPECIFICATION FOR DETAILED CURRENT DERATING CURVES.  
 INSULATION RESISTANCE: >1 X 10<sup>9</sup>Ω AT 500 V<sub>DC</sub>  
 WITHSTANDING VOLTAGE: 1,000V<sub>RMS</sub> AT SEA LEVEL

## 2 ENVIRONMENTAL :

TEMPERATURE RATING: -55°C TO 105°C  
 PROCESS RATING: 260°C, PER J-STD-020C, SINGLE PASS  
 MOISTURE SENSITIVITY LEVEL: 1 (PER J-STD-020C)

1. REGULATORY INFORMATION: ROHS COMPLIANT. SEE THE REGULATORY INFORMATION APPENDIX (RIA) IN THE "ROHS COMPLIANCE" SECTION OF WWW.3MCONNECTORS.COM FOR COMPLIANCE INFORMATION.
2. IN THE EVENT OF CONFLICT BETWEEN THIS DATA AND THAT CONTAINED IN THE PRODUCT SPECIFICATION, THE PRODUCT SPECIFICATION TAKES PRECEDENT.
3. NOTCHES A & C WILL ACCOMMODATE 3M POLARIZING KEY: N3518).
4. MOUNTING HARDWARE: FROM SOLDER SIDE OF PC BOARD USE #4-24 THREAD CUTTING SCREW (3M PART #3341-5) WITH Ø.116 [2.95] MOUNTING HOLE. FOR RIGHT ANGLE VERSION ONLY: #2-56 BOLT AND NUT (3M PART #3341-6) WITH Ø.106 [2.69] MOUNTING HOLE MAY BE USED.
5. THE RECOMMENDED PCB HOLE SIZE FOR THE KINKED TAIL POSITIONS ON THE .112 SOLDER TAIL CONNECTOR IS Ø.035±.002. (SEE K2 VERSION).

## ORDERING INFORMATION

X3XXXXX - XXXXXX

N = HIGH TEMP BLACK (PCT)/(RB PLATING REQ'D)  
 BLANK = (UB PLATING)

3M PART NUMBER:  
(SEE TABLE 1)

PIN CONFIGURATION:  
 1 = RIGHT ANGLE SOLDER TAILS  
 2 = STRAIGHT SOLDER TAILS

PLATING:  
 RB = 30μ" [0.76μm] GOLD AND 200μ" [5.08μm] MATTE TIN (APP. E1 & C1 APPLY)  
 UB = 30μ" [0.76μm] GOLD AND 200μ" [5.08μm] TIN LEAD (APP. E3 & C2 APPLY)

TAIL:  
 02 = FOR .062 [1.57] THICK BOARD  
 03 = FOR .094 TO .125 [2.39 TO 3.18] THICK BOARD  
 K2 = KINKED FOR .062 [1.57] THICK BOARD

LATCH/EJECTOR SYSTEM:  
 0 = NO LATCH/EJECTOR INSTALLED  
 2 = SHORT ROLL PIN LATCH/EJECTORS  
 3 = LONG ROLL PIN LATCH/EJECTORS

3M ELECTRONIC MATERIALS SOLUTIONS DIVISION  
 INTERCONNECT SOLUTIONS  
<http://www.3mconnectors.com>

3M IS A TRADEMARK OF 3M COMPANY.  
 FOR TECHNICAL, SALES OR ORDERING  
 INFORMATION CALL 800-225-5373

DIMENSIONS: INCHES [MM]  
 [MM] IS REF. ONLY



DESIGN REFERENCE	NEXT ASSEMBLY	REV	ECO	ISSUE DATE AND DESCRIPTION	DRFT	CHKD
				AUG 05, 2014		
				REVISED AND REDRAWN	JNC	RS
				AUG 05, 2014		
				APPR. R. SCHERER		DATE SEP 05, 2014
DIVISION: Interconnect Solutions SCALE: 1 DO NOT SCALE DRAWING		DIVISION CODE: EMSD TOLERANCES EXCEPT AS NOTED INCHES: .00 ± .01, .000 ± .005, .0000 ±		3M logo © 3M COPYRIGHT 2015 This document and the information it contains are 3M property and may not be reproduced or further distributed without 3M permission, or used or disclosed other than for 3M authorized purposes. All rights reserved.		
THIRD ANGLE PROJECTION INTERPRET PER ASME Y14.5 - 2009		MILLIMETERS: 0 ± .3, .00 ± .13		TITLE: HEADER, 3-WALL, .100 X .100 LATCH/EJECTOR, STRAIGHT & RA		
MAX SURFACE ROUGHNESS: 12.5 SURFACES <input checked="" type="checkbox"/> MARKED ONLY		ANGLE:		CAGE NUMBER: D78-5100-0771-5 MODEL: 3000 SERIES REV. G		

78-5100-0771-5  
 DRAWING NUMBER  
 9:46 AM UTC-06:00  
 2/13/2015

# 3M™ THREE-WALL HEADER, 3000 SERIES

.100" X .100" LATCH/EJECTOR, STRAIGHT AND RIGHT ANGLE

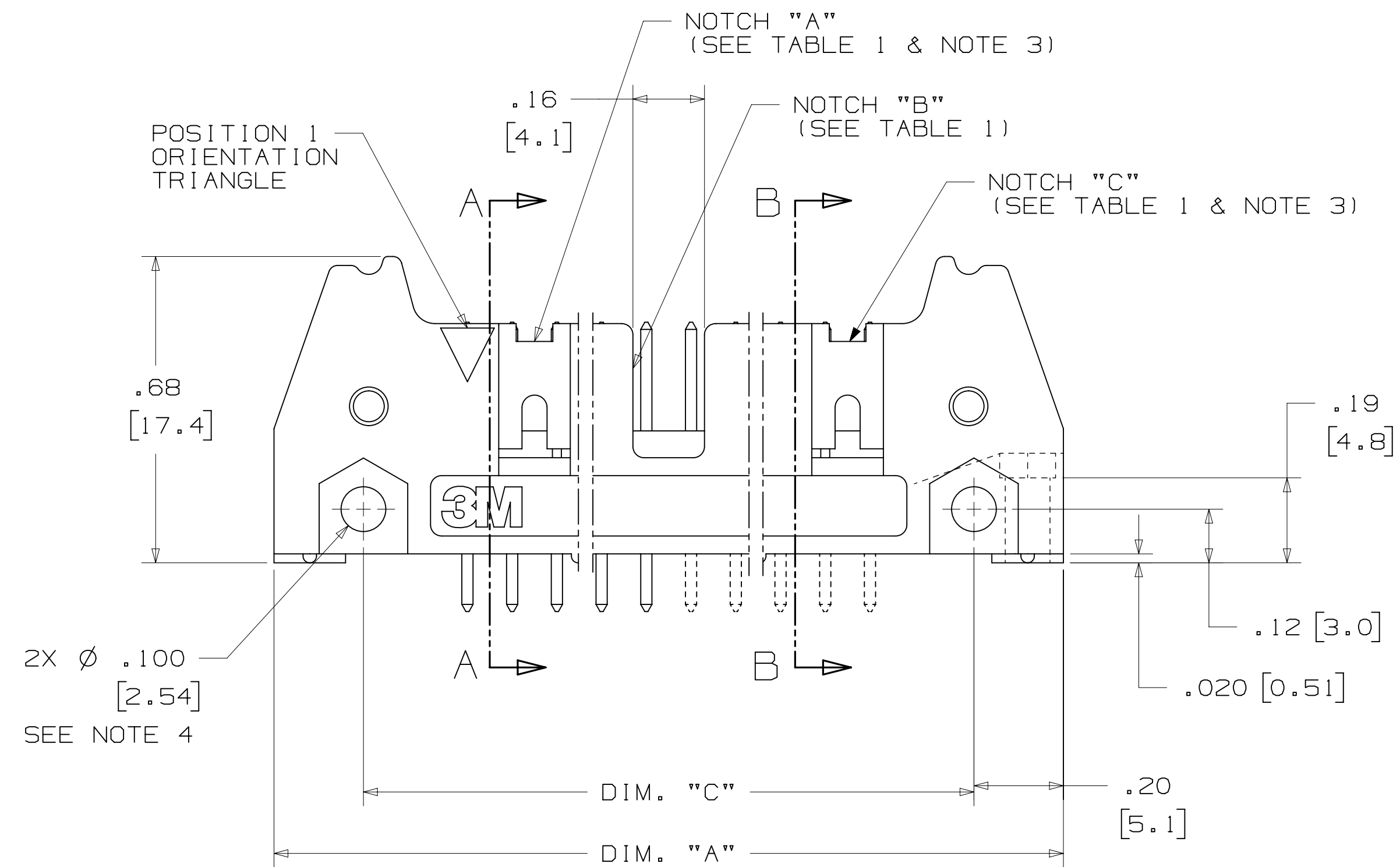
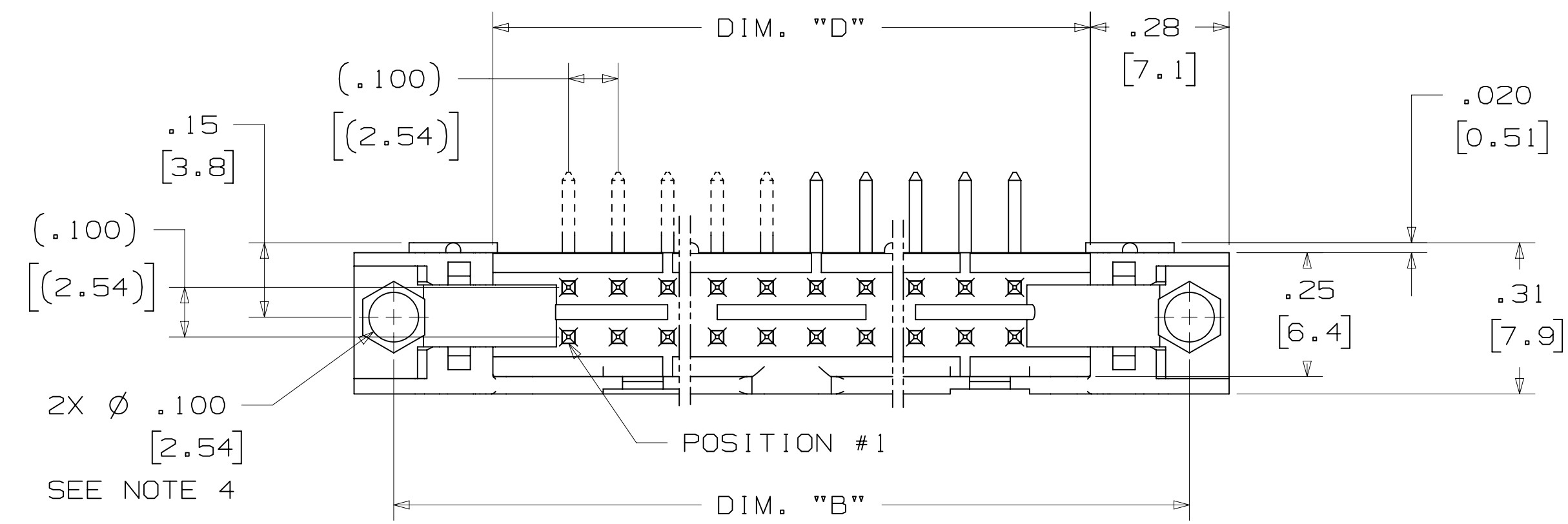
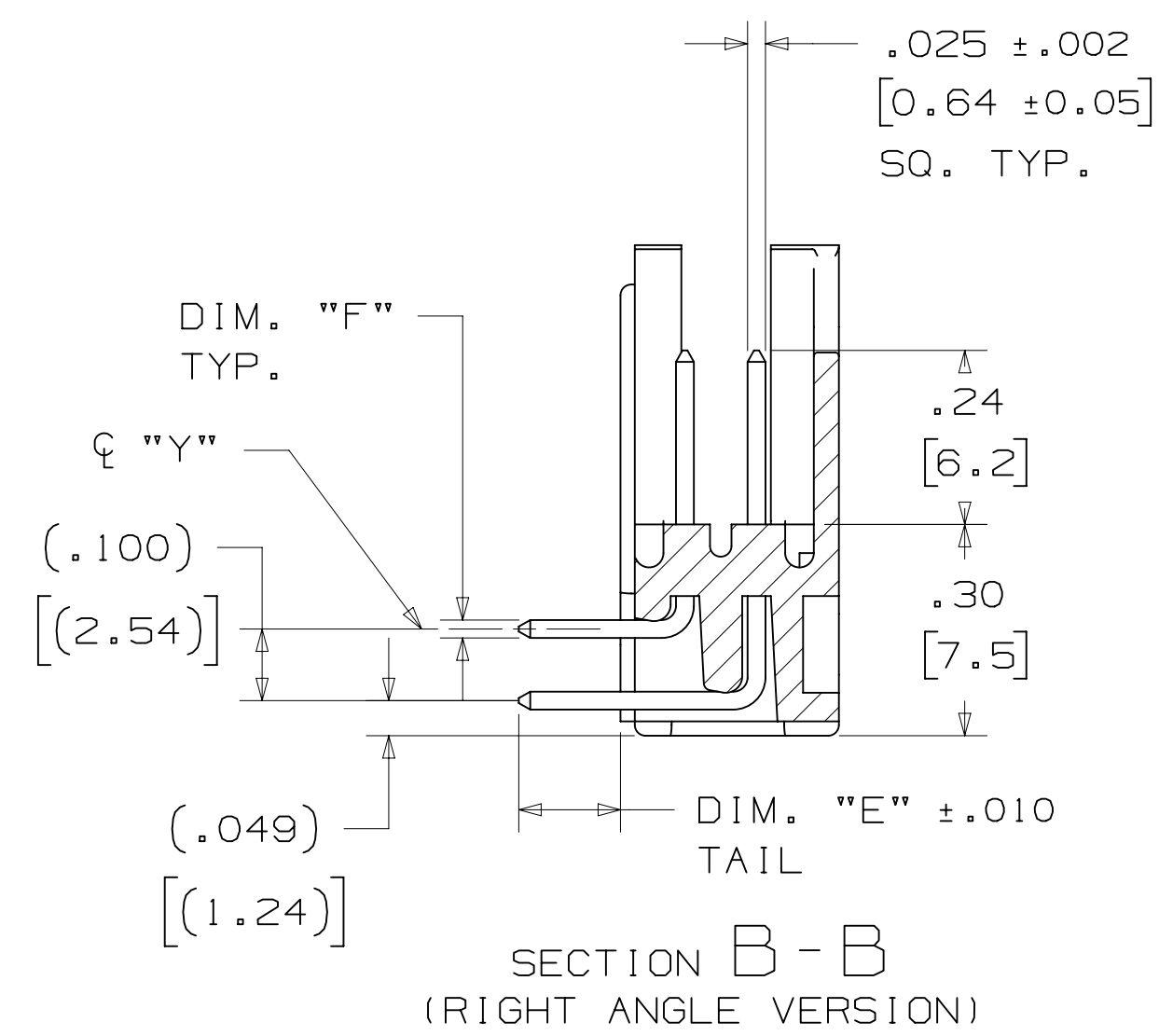
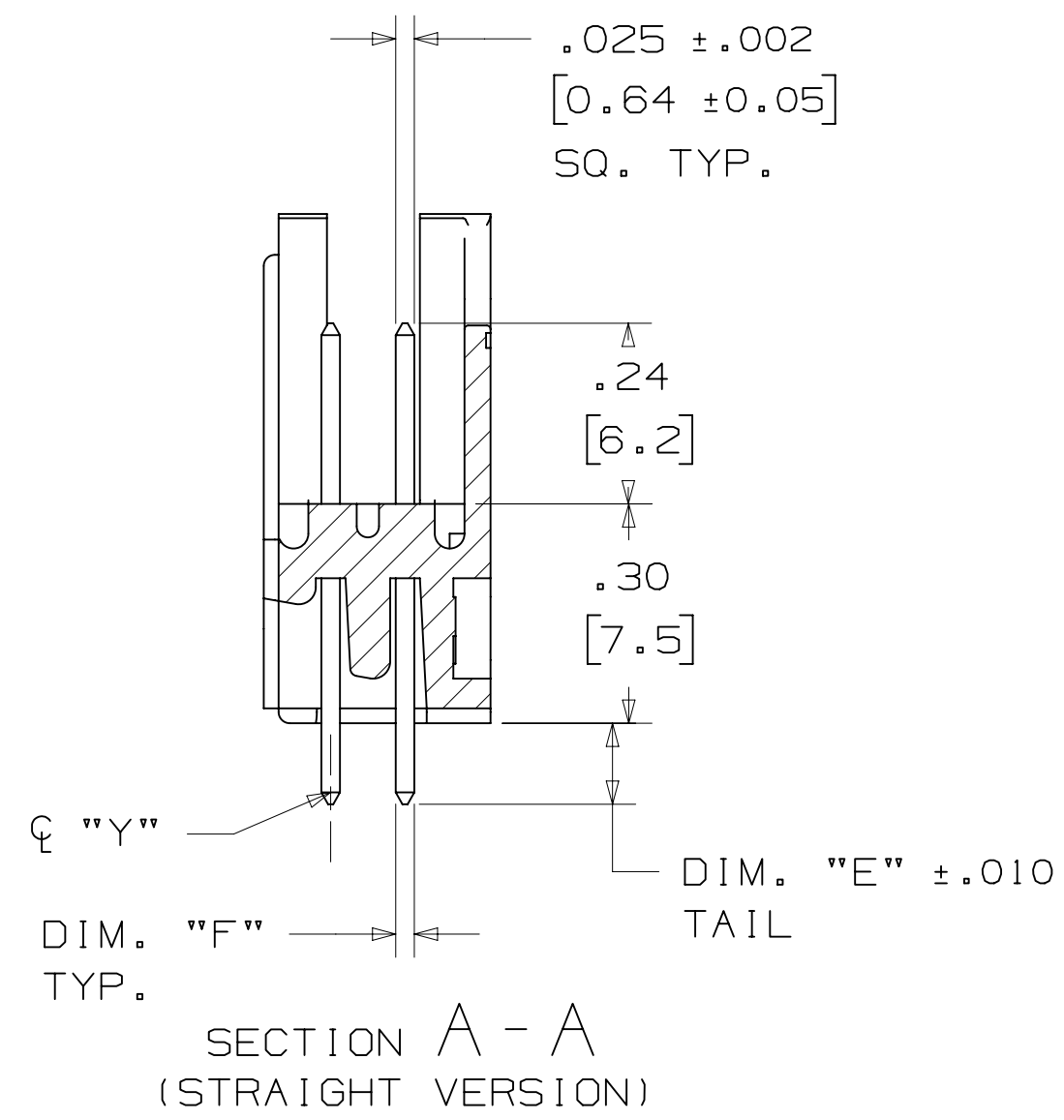

PIN QTY.	3M PART NUMBER	DIM. "A"	DIM. "B"	DIM. "C"	DIM. "D"	POLARIZING NOTCHES	PIN QTY.
10	3793	1.26 [32.1]	1.105 [28.04]	.865 [21.97]	.71 [18.0]	BC	10
14	3314	1.46 [37.2]	1.305 [33.12]	1.065 [27.05]	.91 [23.1]	BC	14
16	3408	1.56 [39.7]	1.405 [35.66]	1.165 [29.59]	1.01 [25.6]	ABC	16
20	3428	1.76 [44.8]	1.604 [40.74]	1.365 [34.67]	1.21 [30.7]	ABC	20
26	3429	2.06 [52.4]	1.905 [48.36]	1.665 [42.29]	1.51 [38.3]	ABC	26
34	3431	2.46 [62.6]	2.305 [58.52]	2.065 [52.45]	1.91 [48.5]	ABC	34
40	3432	2.76 [70.2]	2.605 [66.14]	2.365 [60.07]	2.21 [56.1]	ABC	40
50	3433	3.26 [82.9]	3.105 [78.84]	2.865 [72.77]	2.71 [68.8]	ABC	50
60	3372	3.76 [95.6]	3.605 [91.54]	3.365 [85.47]	3.21 [81.5]	ABC	60
64	3764	3.96 [100.7]	3.805 [96.62]	3.565 [90.55]	3.41 [86.6]	ABC	64

3M PART NUMBER SUFFIX	CONTACT TAIL	DIM. "E"	PIN CROSS SECTION			DIM. "G"
-1XX2	.062 [1.57] THICK PC BOARD	.112 [2.84]	DIM. "F"			.035+/- .003 [.89] SEE NOTE 5
-2XX2			.0245+/- .0005 [.622]	.028+/- .001 [.71]	CORNER RADIUS .0075 REF. [.191]	
-1X03	.094 [2.39] TO .125 [3.18] THICK PC BOARD	.155 [3.94]	DIM. "F"			.035+/- .003 [.89]
-2X03			.0245+/- .0005 [.622]	.028+/- .001 [.71]	.0075 REF. [.191]	

DESIGN REFERENCE	NEXT ASSEMBLY	REV	ECO	ISSUE DATE AND DESCRIPTION	DRFT	CHKD
				AUG 05, 2014		
DIVISION		3M Center		St. Paul, MN 55144		
Interconnect Solutions		EMSD		DATE		
DO NOT SCALE DRAWING		SCALE 4/1		TOLERANCES EXCEPT AS NOTED		
THIRD ANGLE PROJECTION		INCHES		MILLIMETERS		
INTERPRET PER ASME Y14.5 - 2009		0 ± .01		.000 ± .005		
MAX SURFACE ROUGHNESS		0 ± .3		.000 ± .13		
MARKED ONLY		ANGLES		CAGE NUMBER		
				D 78-5100-0771-5		
				MODEL 3000 SERIES		
				REV. G		

78-5100-0771-5  
 DRAWING NUMBER  
 6  
 REVISION  
 AM UTC-06:00  
 9:46 AM 2/13/2015

# 3M™ THREE-WALL HEADER, 3000 SERIES

.100" X .100" LATCH/EJECTOR, STRAIGHT AND RIGHT ANGLE

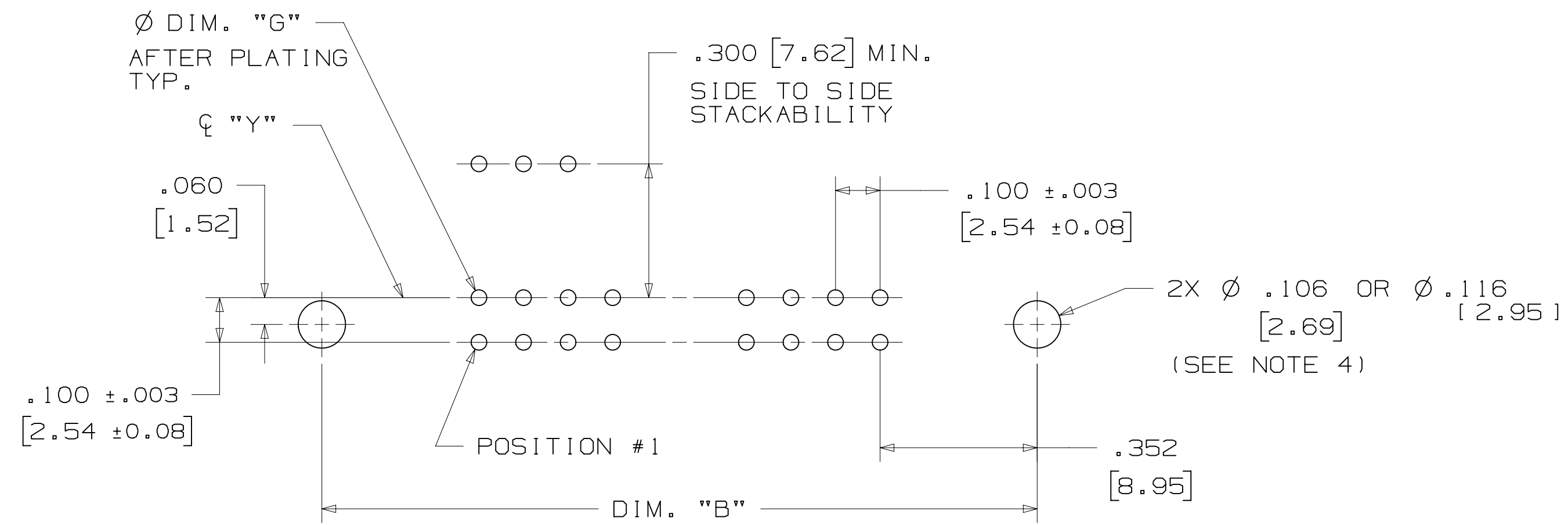

RECOMMENDED MOUNTING HOLE PATTERN  
(STRAIGHT VERSION)



RECOMMENDED MOUNTING HOLE PATTERN  
(RIGHT ANGLE VERSION)

## PART CUSTOMIZATION

THIS SPEC SHEET DETAILS OUR STANDARD OFFERING.

3M HAS SEVERAL CAPABILITIES THAT CAN PROVIDE A PART TAILORED TO YOUR SPECIFIC NEEDS. ASK YOUR 3M SALES REPRESENTATIVE OR CUSTOMER SERVICE FOR MORE DETAILS.

BOTH SNAP-IN AND ROLL PIN LATCHES MAY BE ORDERED SEPARATELY. SNAP-IN AND ROLL PIN STYLE LATCHES ARE DIMENSIONALLY AND FUNCTIONALLY EQUIVALENT. IF ORDERING SNAP-IN OR ROLL PIN STYLE LATCHES SEPARATELY, PLEASE USE THE BELOW CHART.

MATERIAL	SHORT LATCH	LONG LATCH	LATCH STYLE	COLOR
HIGH TEMP. (PCT)	N3505-2B	N3505-3B	ROLL PIN	BLACK
HIGH TEMP (PPA)	N3505-30B	N3505-31B	SNAP-IN	BLACK

- \* SELECTIVE PIN REMOVAL (ATA OR OTHER COMPATABILITY)
- \* WIRE WRAP TAILS STYLE

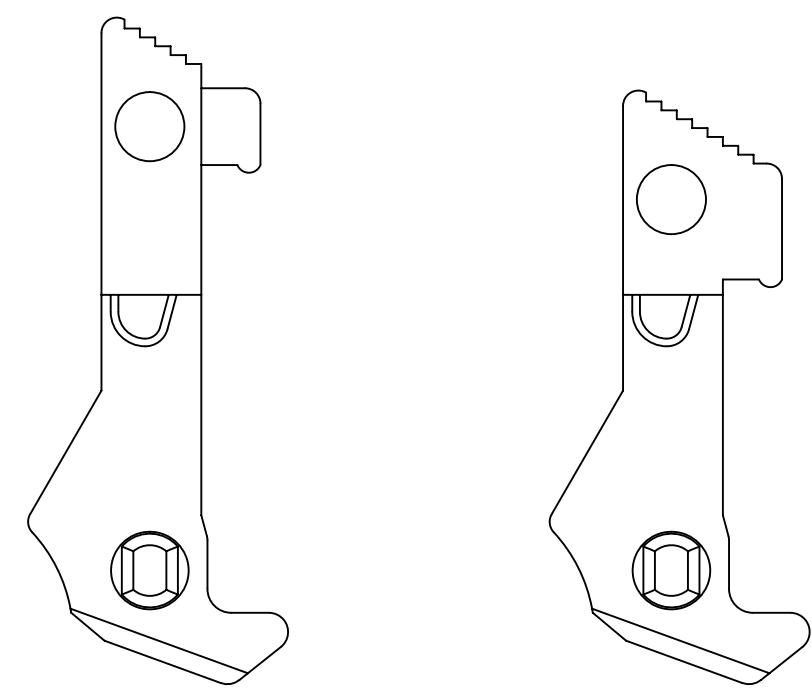

LONG

SHORT

## SNAP-IN LATCHES

NOTE:  
SNAP-IN LATCHES CAN ONLY BE ORDERED SEPARATELY AND ARE THE CUSTOMERS RESPONSIBILITY TO INSTALL.

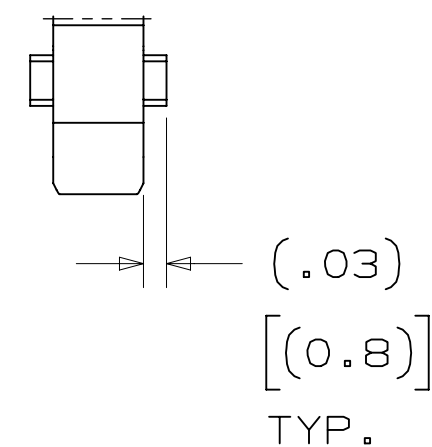

## POLARIZING POST

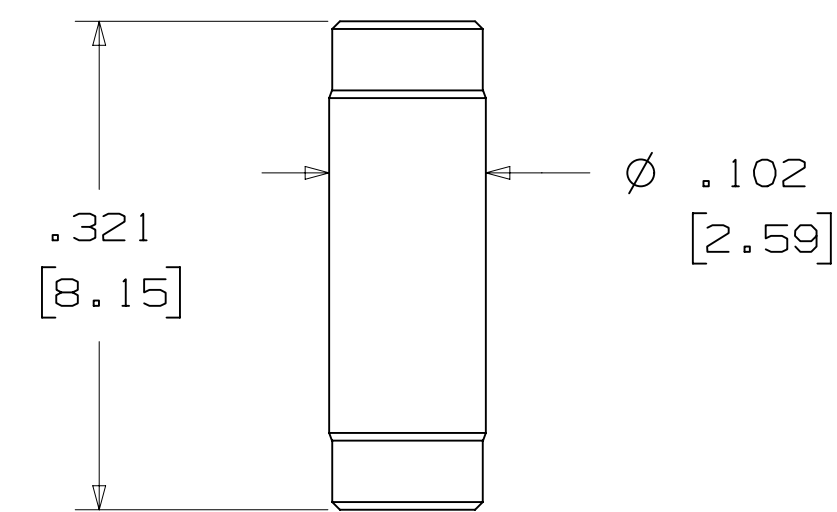

3M PART NO.	MATERIAL	COLOR
3201-4	LCP	BLACK

NOTE:  
INSERT POST INTO ONE MOUNTING HARDWARE HOLE ON BOTTOM OF HEADER. SET POST TO PROTRUDE .115 [2.92]

## (K2) OPTION

2500 & 3000 SERIES SHROUDED HEADER						
TOTAL NO. OF PINS	NO. OF TAILS KINKED	POSITIONS KINKED				
10	4	3	4	7	8	
14	4	3	4	11	12	
16	4	3	4	13	14	
20	4	3	4	17	18	
26	4	3	4	23	24	
34	4	7	8	27	28	
40	4	7	8	33	34	
50	4	7	8	43	44	
60	4	11	12	49	50	
64	4	11	12	53	54	

KINKED TAIL DETAIL:  
- KINK IS LOCATED .05" BELOW BOTTOM SURFACE OF PLASTIC.  
- EXTERNAL RADIUS OF KINK TOWARD PART CENTERLINE.

## POLARIZING KEY

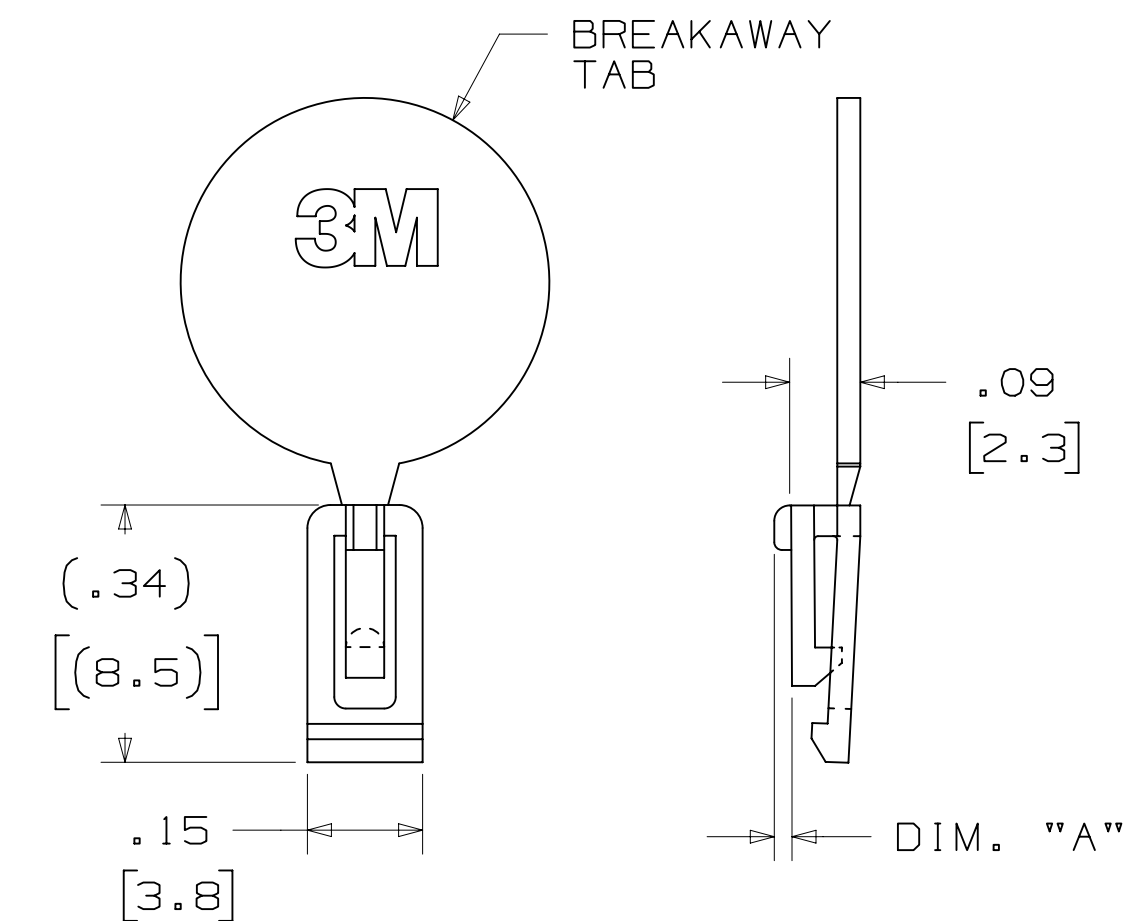

3M PART NO.	MATERIAL	COLOR	DIM. "A"
N3518	LCP	BLACK	.02

NOTE:  
#2216 B/A SCOTCHWELD CAN BE USED TO ADHERE KEYS.

DESIGN REFERENCE	NEXT ASSEMBLY	REV	ECO	ISSUE DATE AND DESCRIPTION	DRFT	CHKD
				AUG 05, 2014	JNC	RS
				REVISED AND REDRAWN		
DATE	DATE	DATE	DATE	DATE	DATE	DATE
CASTIGLIONE	AUG 05, 2014	MFG				
CHKD		APPV				
		R. SCHERER				SEP 05, 2014
DIVISION		DIVISION CODE		DATE		
Interconnect Solutions		EMSD		3M Center St. Paul, MN 55144		
DO NOT SCALE DRAWING	SCALE 4/1	TOLERANCES EXCEPT AS NOTED		© 3M COPYRIGHT 2015		
		INCHES		This document and the information it contains are 3M property and may not be reproduced or further distributed without 3M permission, or used or disclosed other than for 3M authorized purposes. All rights reserved.		
		MILLIMETERS		TITLE		
		0 ±		HEADER, 3-WALL, .100 X .100 LATCH/EJECTOR, STRAIGHT & RA		
		.00 ± .01		CAGE NUMBER		
		.000 ± .005		D78-5100-0771-5		
		.0000 ±		REV.		
		.0 ± .3		G		
		.00 ± .13		MODEL		
		.000 ±		3000 SERIES		
		ANGLES		DET		
				LISTS YES X NO SHT 3 OF 4		

178-5100-0771-5  
 9:46 AM UTC-06:00  
 6 REVISION  
 DRAWING NUMBER

3M™ THREE-WALL HEADER, 3000 SERIES  
 .100" X .100" LATCH/EJECTOR, STRAIGHT AND RIGHT ANGLE

MOUNTING HARDWARE

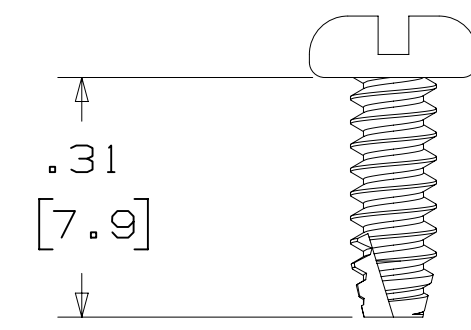

**3341-5**  
 (INSTALL FROM BOTTOM OF BOARD)  
 PANHEAD THREAD CUTTING SCREW:  
 #4-24 X 5/16"  
 TYPE: USA STD BT, FEDERAL B6  
 MATERIAL: STAINLESS STEEL

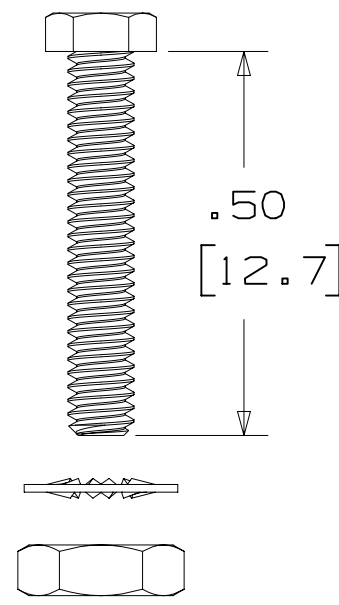

**3341-6**  
 HEX HEAD BOLT, NUT AND WASHER:  
 BOLT - #2-56 X 1/2"  
 MATERIAL: STAINLESS STEEL

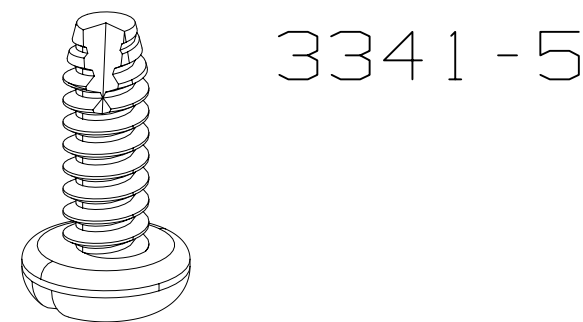
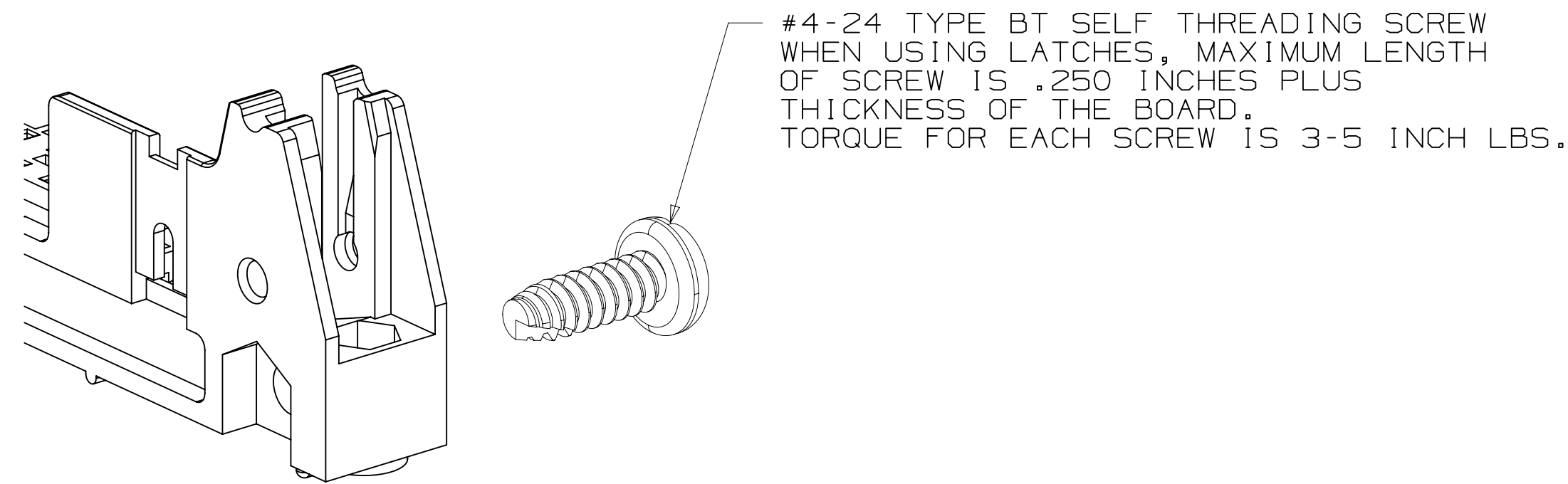
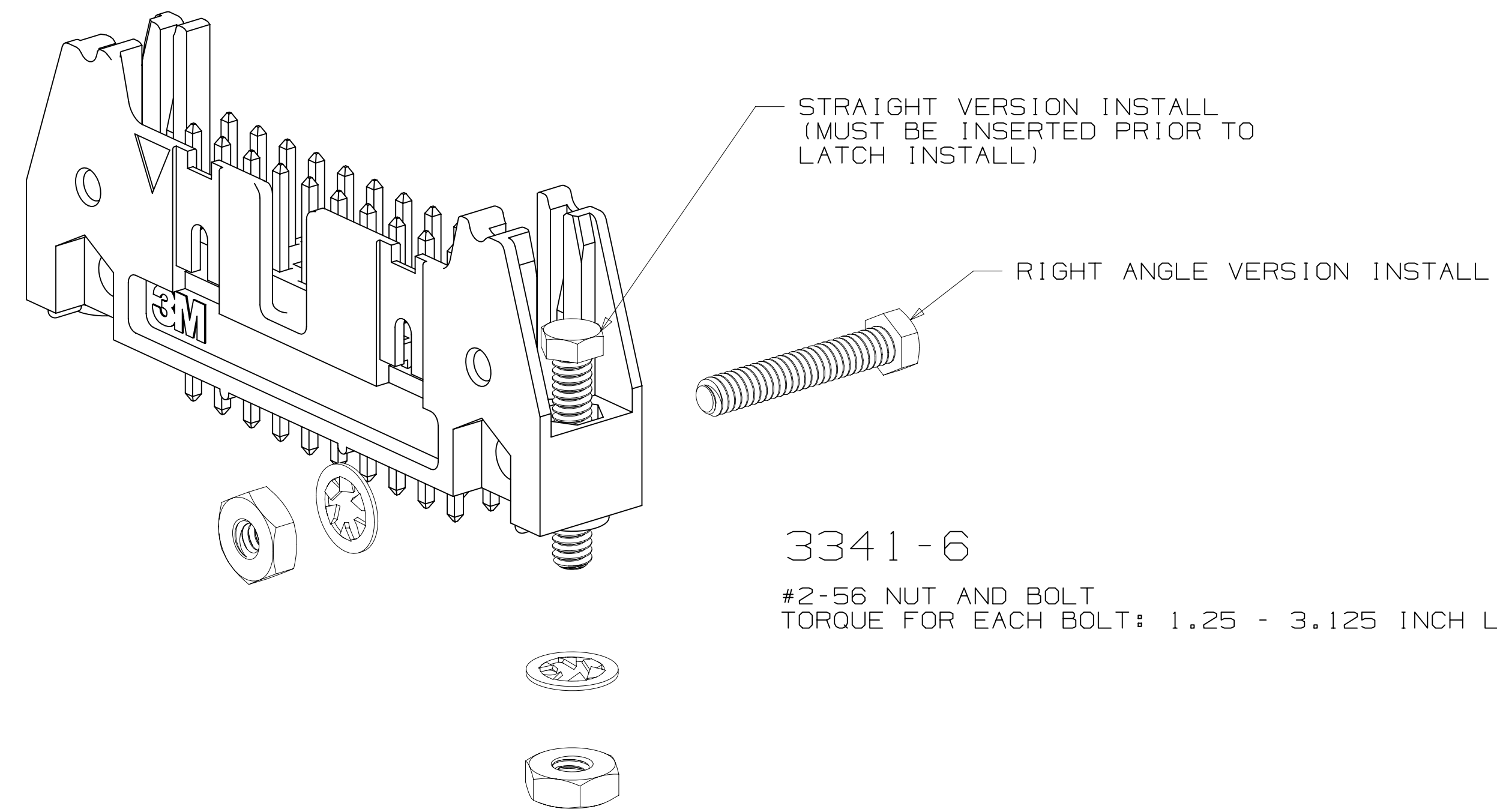

**3341-5**

DESIGN REFERENCE		NEXT ASSEMBLY		REV	ECO	ISSUE DATE AND DESCRIPTION	DRFT	CHKD
G 56068		AUG 05, 2014				REVISED AND REDRAWN	JNC	RS
CAGE NUMBER		DRAWING NO.		DATE		DATE		DATE
D 78-5100-0771-5		G		AUG 05, 2014		AUG 05, 2014		SEP 05, 2014
DIVISION		DIVISION CODE		APPRV		DATE		DATE
Interconnect Solutions		EMSD		R. SCHERER		SEP 05, 2014		
DO NOT SCALE DRAWING		SCALE 4/1		TOLERANCES EXCEPT AS NOTED		INCHES		
THIRD ANGLE PROJECTION		INTERPRET PER ASME Y14.5 - 2009		MILLIMETERS		0 ±		
MAX SURFACE ROUGHNESS		SURFACES		0 ±		.3 ±		
MARKED ONLY		ANGLES		.00 ±		.13 ±		
TITLE		CAGE NUMBER		DRAWING NO.		REV.		
HEADER, 3-WALL, .100 X .100 LATCH/EJECTOR, STRAIGHT & RA		D 78-5100-0771-5		G		G		
MODEL		3000 SERIES		DET		IS1S		YES X NO SHT 4 OF 4

78-5100-0771-5  
 DRAWING NUMBER  
 6  
 REVISION  
 AM UTC-06:00  
 9:46  
 2/13/2015