

4.0A 4Quadrants TRIACs

Product Summary

Symbol	Value	Unit
$I_{T(RMS)}$	4.0	A
$V_{DRM} V_{RRM}$	600/800	V
V_{TM}	1.55	V

Features

With high ability to withstand the shock loading of large current, With high commutation performances, 4 quadrants products especially recommended for use on inductive load.

Application

Washing machine, vacuums, massager, solid state relay, AC Motor speed regulation and so on.

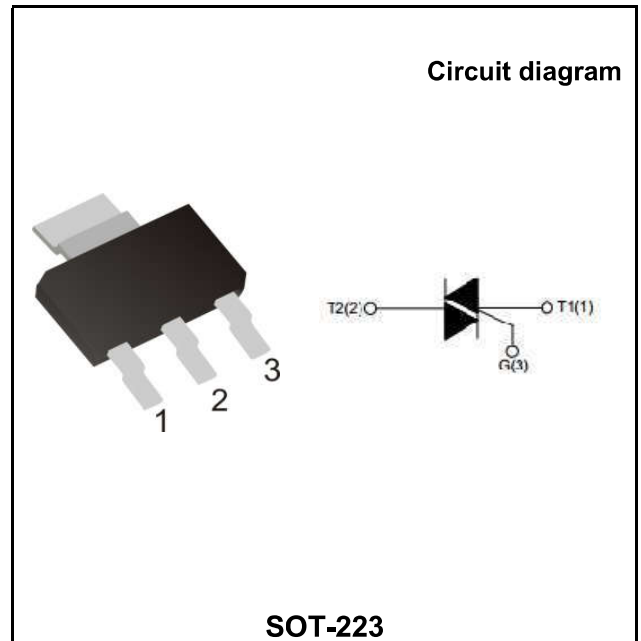

Order Information

Part Number	Package	Marking	Delivery Form	Delivery Quantity
BT134W	SOT-223	BT134W XXXX	13" T&R	2500PCS/Tape

Absolute maximum ratings (Ta=25°C unless otherwise noted)

Parameter	Symbol	Value	Unit
Repetitive peak off-state voltage	V_{DRM}	600/800	V
Repetitive peak reverse voltage	V_{RRM}	600/800	V
RMS on-state current	$I_{T(RMS)}$	4	A
Non repetitive surge peak on-state current (full cycle, F=50Hz)	I_{TSM}	25	A
I^2t value for fusing (tp=10ms)	I^2t	3.1	A ² s
Critical rate of rise of on-state current ($I_G = 2 \times I_{GT}$)	di_T/dt	I - II - III	50
		IV	10
Peak gate current	I_{GM}	2	A
Gate peak power	P_{GM}	5	W
Average gate power dissipation	$P_G(AV)$	0.5	W
Junction Temperature	T_J	-40 ~+125	°C
Storage Temperature	T_{STG}	-40 ~+150	°C

Electrical characteristics (TA=25°C, unless otherwise noted)

Parameter	Symbol	Test Condition	Value		Unit	
			D	E		
Gate trigger current	I_{GT}	$V_D=12V$ $I_T=0.1A$ $T_j=25^\circ C$ Fig.6	I - II - III	≤ 5	≤ 10	mA
			IV	≤ 10	≤ 25	
Gate trigger voltage	V_{GT}	I - II - III - IV	≤ 1.3		V	
Gate non-trigger voltage	V_{GD}	$V_D = V_{DRM}, T_j = 125^\circ C$	≥ 0.2		V	
Holding current	I_H	$V_D = 12V$ $I_{GT} = 0.1A$ $T_j = 25^\circ C$ Fig.6	I - II - III - IV	≤ 10	≤ 15	mA
Latching current	I_L		I - III - IV	≤ 10	≤ 15	
			II	≤ 15	≤ 20	mA
Critical-rate of rise of commutation voltage	dV_D/dt	$V_D = 2/3 V_{DRM}$ Gate Open $T_j = 125^\circ C$	≥ 10	≥ 20	V/us	

STATIC CHARACTERISTICS

Forward "on" voltage	V_{TM}	$I_{TM} = 6A, T_P = 380\mu s, \text{FIG.4}$	≤ 1.55		V	
Repetitive Peak Off-State Current	I_{DRM}	$V_D = V_{DRM} V_R = V_{RRM}$	$T_j = 25^\circ C$	≤ 5	≤ 5	uA
Repetitive Peak Reverse Current	I_{RRM}		$T_j = 125^\circ C$	≤ 0.5	≤ 0.5	mA

THERMAL RESISTANCES

Thermal resistance	$R_{th(j-c)}$	Junction to case(AC)	TYP.	23	$^\circ C/W$
	$R_{th(j-a)}$	Junction to ambient	S=5cm ²	TYP.	60

Ordering Information

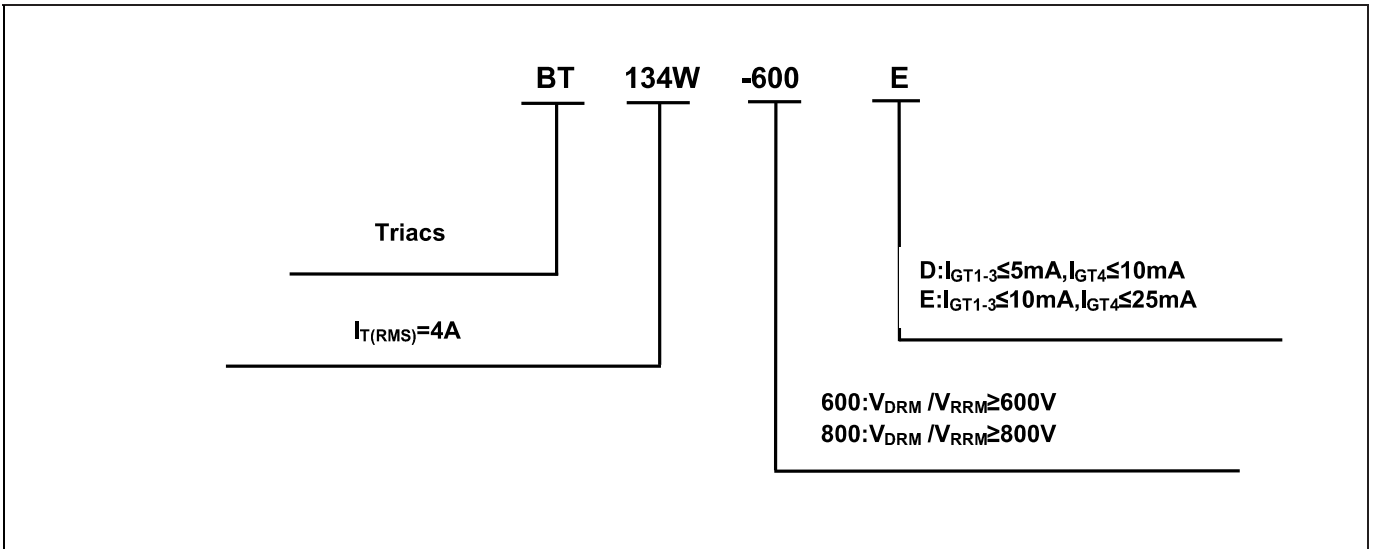

Typical Characteristics

FIG1 Maximum power dissipation versus RMS on-state current

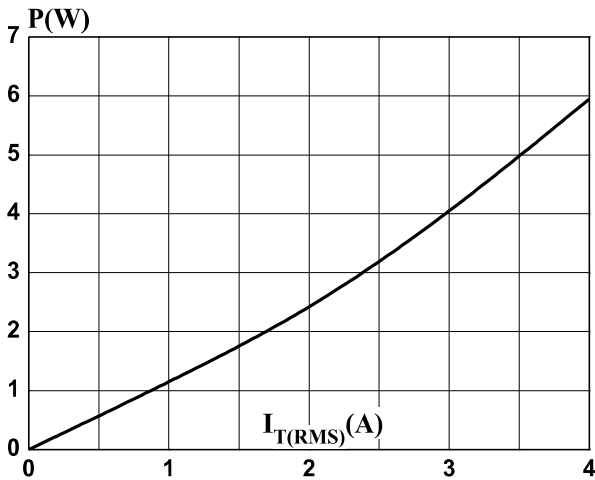

FIG2 RMS on-state current versus case temperature

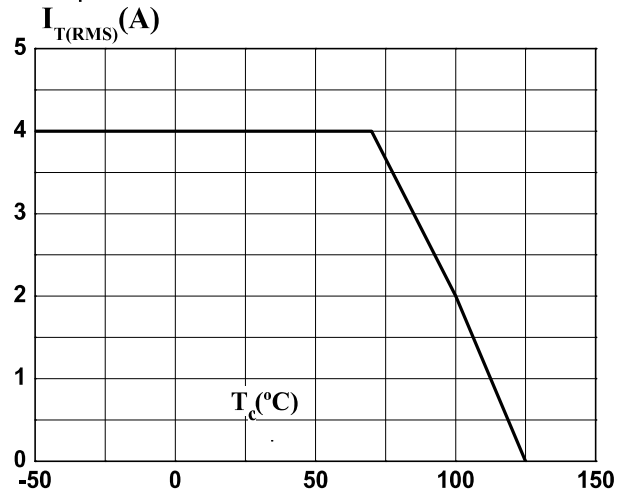

FIG3 Surge peak on-state current versus number of cycles

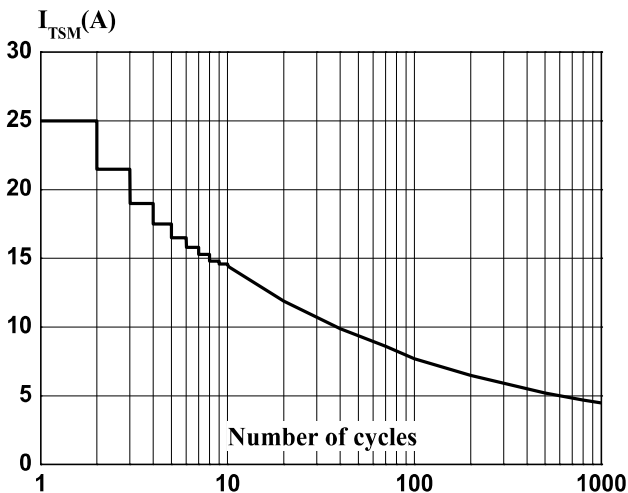

FIG4 On-state characteristics (maximum values)

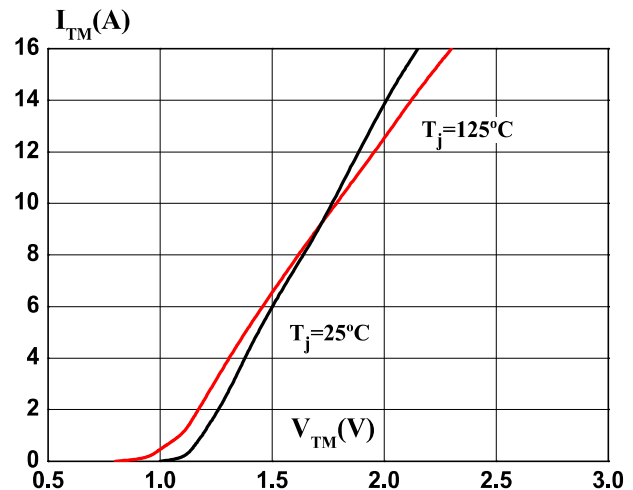

FIG5 Non-repetitive surge peak on-state current for a sinusoidal pulse with width $t_p < 20\text{ms}$, and corresponding value of I^2t ($dI/dt < 100\text{A}/\mu\text{s}$)

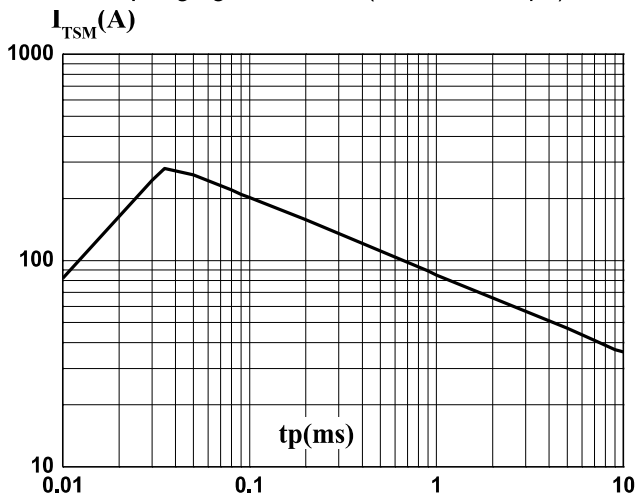
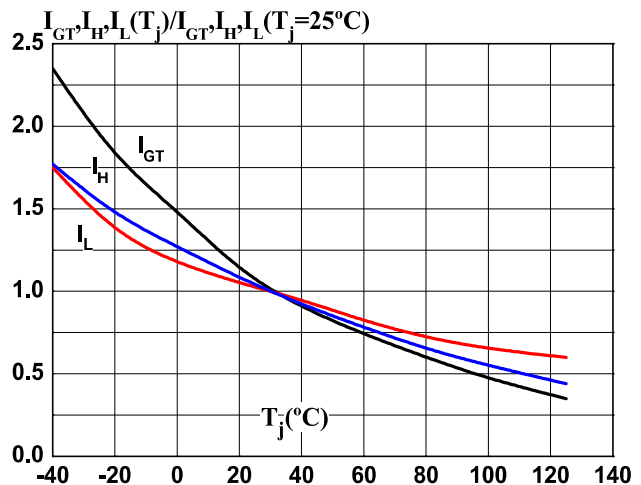
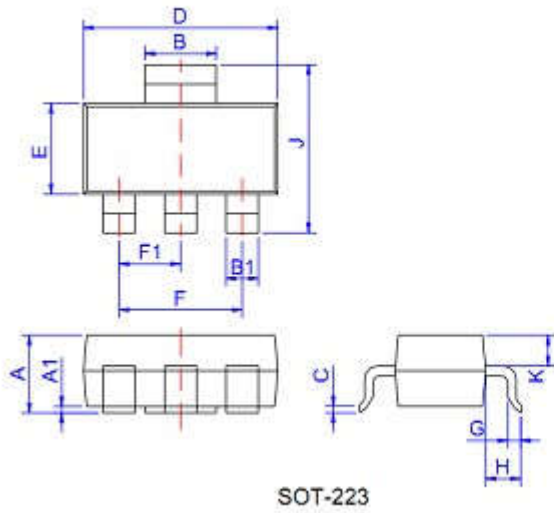

FIG6 Relative variations of gate trigger current, holding current and latching current versus junction temperature



Package Information

SOT-223



Ref.	Dimensions					
	Millimeters			Inches		
	Min.	Typ.	Max.	Min.	Typ.	Max.
A	1.5	1.6	1.8	0.059	0.063	0.071
A1	0.01	0.06	0.10	0.001	0.002	0.004
B	2.9	3.0	3.1	0.114	0.118	0.122
B1	0.6	0.7	0.8	0.024	0.028	0.031
C	0.22	0.26	0.32	0.009	0.010	0.013
D	6.3	6.5	6.7	0.248	0.256	0.264
E	3.3	3.5	3.7	0.130	0.138	0.146
F		4.6			0.181	
F1		2.3			0.091	
G	0.7	0.9	1.1	0.028	0.035	0.043
H	1.5	1.75	2	0.059	0.069	0.079
J	6.7	7.0	7.3	0.264	0.276	0.287
K		0.9			0.035	