

General Description

The ULN2003A is high-voltage high-current Darlington transistor arrays each containing seven open collector common emitter pairs. Each pair is rated at 500mA. Suppression diodes are included for inductive load driving, the inputs and outputs are pinned in opposition to simplify board layout.





These devices are capable of driving a wide range of loads including solenoids, relays, DC motors, LED displays, filament lamps, thermal print-heads and high-power buffers.

The ULN2003A is available in both a small outline 16-pin package (DIP-16, SOP16, TSSOP16).

Features

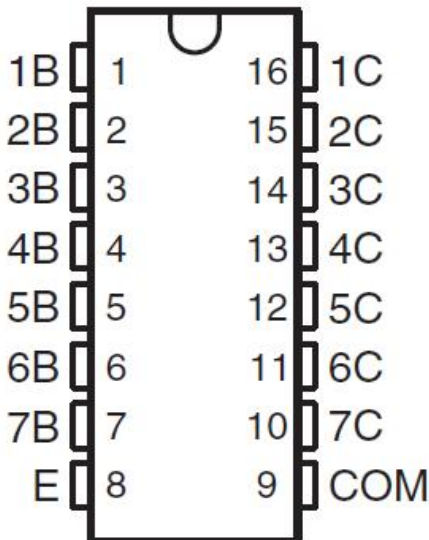
- 500-mA-Rated Collector Current(single output)
- High-Voltage Outputs:50V
- Output Clamp Diodes
- Inputs Compatible With Various Types of Logic
- Relay-Driver Applications

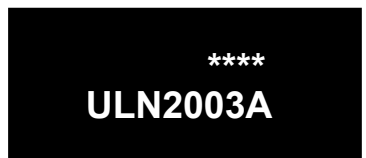
Encapsulation form and pin definition function

Pin Assignments	Marking
<p style="text-align: center;">(TOP VIEW)</p> 	<div style="text-align: center;">  <p>ULN2003 *****</p> <p>SOP-16</p> </div>
	<div style="text-align: center;">  <p>**** ULN2003A</p> <p>TSSOP16</p> </div>
	<div style="text-align: center;">  <p>ULN2003AN *****</p> <p>DIP-16</p> </div>

Connection Diagram

LOGIC DIAGRAM

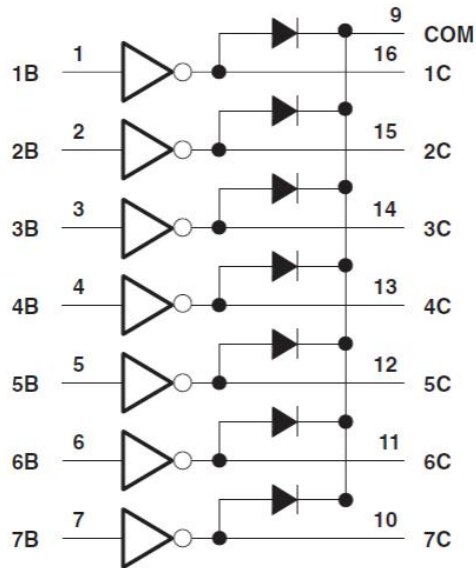

Pin Descriptions

Pin Number	Pin Name	Function
1	1B	Input pair1
2	2B	Input pair1
3	3B	Input pair1
4	4B	Input pair1
5	5B	Input pair1
6	6B	Input pair1
7	7B	Input pair1
8	E	Common Emitter (ground)
9	COM	Common Clamp Diodes
10	7C	Output pair7
11	6C	Output pair6
12	5C	Output pair5
13	4C	Output pair4
14	3C	Output pair3
15	2C	Output pair2
16	1C	Output pair1

Functional Block Diagram

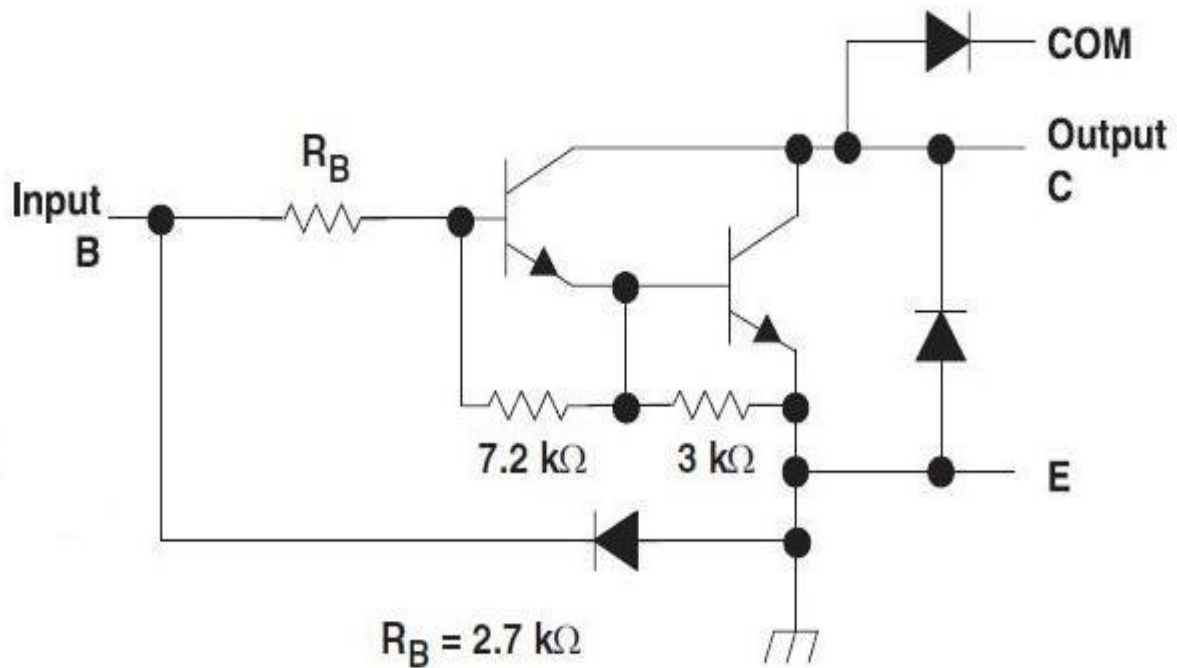

Note: All resistor values shown are nominal.

The collector-emitter diode is a parasitic structure and should not be used to conduct current. If the collector(s) go below ground an external Schottky diode should be added to clamp negative undershoots.

Order Information

Designator	Package	Packing type
ULN2003	SOP-16	3500
ULN2003APWR	TSSOP16	4000
ULN2003AN	DIP-16	25

Absolute Maximum Ratings ⁽¹⁾

At 25°C free-air temperature (unless otherwise noted)

Symbol	Parameter		Min	Max	Unit
V _{CC}	Collector to emitter voltage			50	V
V _R	Clamp diode reverse voltage(2)			50	V
V _I	Input voltage(2)			30	V
I _{CP}	Peak collector current	See typical characteristics		500	mA
I _{OK}	Output clamp current			500	mA
I _{TE}	Total emitter-terminal current			-2.5	A
T _A	Operating free-air temperature range	ULN2003Axxx-MS	-40	+105	°C
θ _{JA}	Thermal Resistance Junction-to-Ambient(3)			63	°C/W
θ _{JC}	Thermal Resistance Junction-to-Case(4)			12	
T _J	Operating virtual junction temperature			+150	°C
T _{STG}	Storage temperature range		-65	+150	°C
ESD	Human Body Mode		--	3000	V

(1) =Stresses beyond those listed under "absolute maximum ratings" may cause permanent damage to the device.

These are stress ratings only, and functional operation of the device at these or any other conditions beyond those indicated under "recommended operating conditions" is not implied. Exposure to absolute-maximum-rated conditions for extended periods may affect device reliability.

(2) All voltage values are with respect to the emitter/substrate terminal E, unless otherwise noted.

(3) Maximum power dissipation is a function of T_{J(max)}, θ_{JA}, and T_A. The maximum allowable power dissipation at any allowable ambient temperature is $PD = (T_J(max) - T_A)/\theta_{JA}$. Operating at the absolute maximum T_J of 150°C can affect reliability.

(4) Maximum power dissipation is a function of T_{J(max)}, θ_{JC}, and T_A. The maximum allowable power dissipation at any allowable ambient temperature is $PD = (T_J(max) - T_A)/\theta_{JC}$. Operating at the absolute maximum T_J of 150°C can affect reliability.

Recommended Operating Conditions

Symbol	Parameter	Min	Max	Unit
V _{CC}	Collector to Emitter voltage	-	50	V
T _A	Operating Ambient Temperature	-40	+85	°C

Electrical Characteristics (TA=+25°C, unless otherwise specified)

Parameter		Test Figure	Test Conditions		ULN2003A			Unit
					MIN	TYP	MAX	
V _{I(on)}	On-state input voltage	Figure 6	VCE = 2 V	IC = 200 mA	--	--	2.4	V
				IC = 250 mA	--	--	2.7	
				IC = 300 mA	--	--	3	
V _{CE(sat)}	Collector-emitter saturation voltage	Figure 5	II = 250 μA, IC = 100 mA	--	0.9	1.1	V	
			II = 350 μA, IC = 200 mA	--	1	1.3		
			II = 500 μA, IC = 350 mA	--	1.2	1.6		
I _{CEX}	Collector cutoff current	Figure 1	VCE = 50 V, II = 0	--	--	50	μA	
		Figure 2	VCE = 50 V, TA = +105°C, II = 0	--	--	100		
V _F	Clamp forward voltage	Figure 8	IF = 350 mA	--	1.7	2	V	
I _{I(off)}	Off-state input current	Figure 3	VCE = 50 V, IC = 500 μA	50	65	--	μA	
II	Input current	Figure 4	VI = 3.85 V	--	0.93	1.35	mA	
			VI = 5 V	--	--	--		
			VI = 12 V	--	--	--		
IR	Clamp reverse current	Figure 7	VR = 50 V		--	--	50	μA
				TA = 70°C	--	--	100	
Ci	Input capacitance		VI = 0, f = 1 MHz	--	15	25	pF	

Switching Characteristics (TA = +25°C, unless otherwise specified)

Parameter		Test Conditions	ULN2003A			UNIT
			MIN	TYP	MAX	
t _{PLH}	Propagation delay time, low- to high-level output	See Figure 9		0.25	1	μs
t _{PHL}	Propagation delay time, high- to low-level output	See Figure 9		0.25	1	μs
V _{OH}	High-level output voltage after switching	VS = 50 V, IO = 300 mA, See Figure 9	VS-20			mV

Parameter Measurement Information

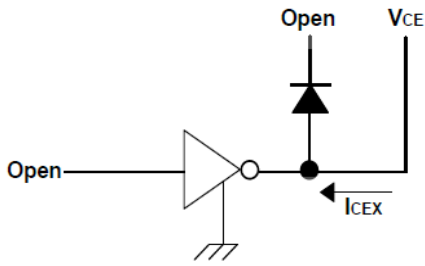

Fig.1 ICEX Test Circuit

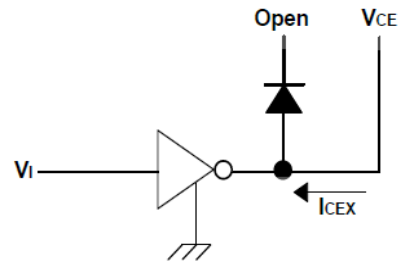

Fig.2 ICEX Test Circuit

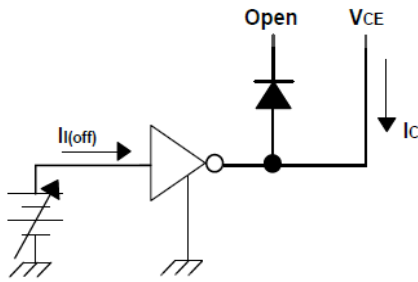

Fig.3 I(off) Test Circuit

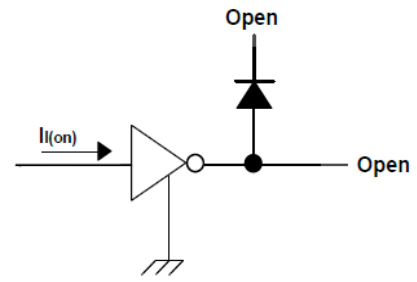

Fig.4 I(on) Test Circuit

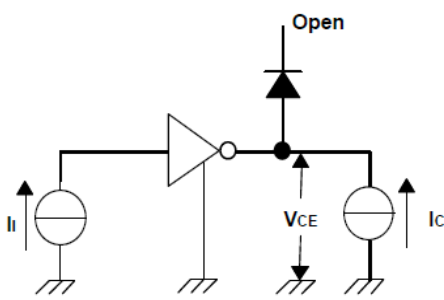

Fig. 5 h_{FE} , $V_{CE(sat)}$ Test Circuit

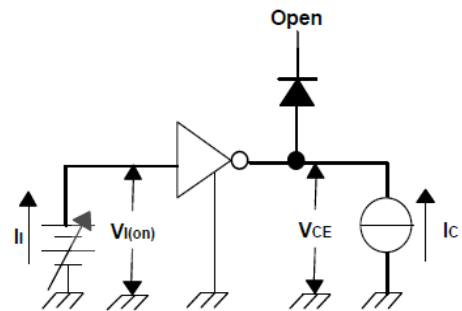

Fig. 6 $V_{I(on)}$ Test Circuit

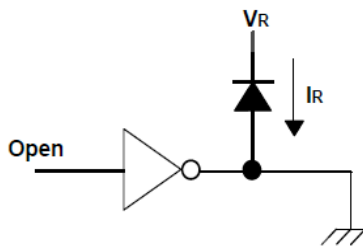

Fig. 7 I_R Test Circuit

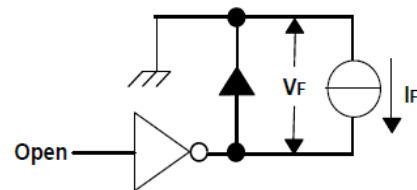

Fig. 8 V_F Test Circuit

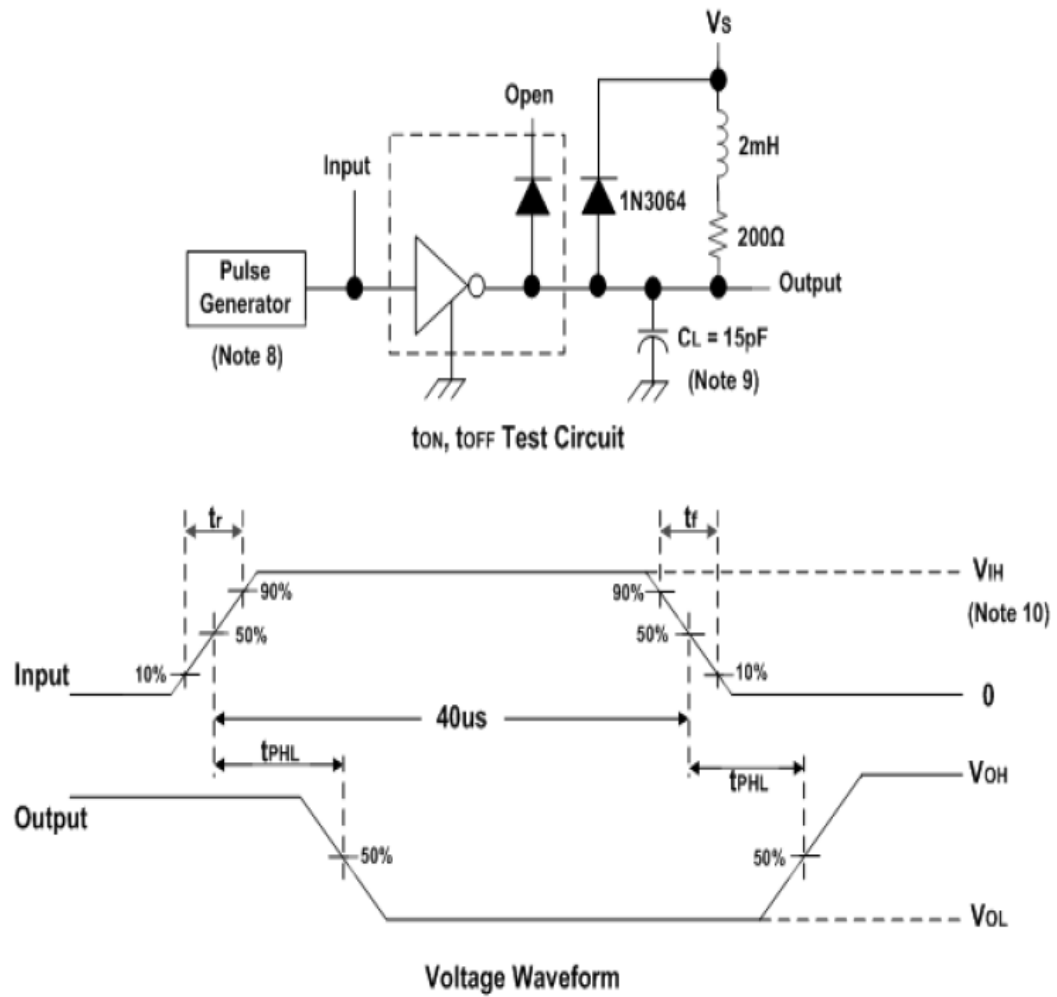
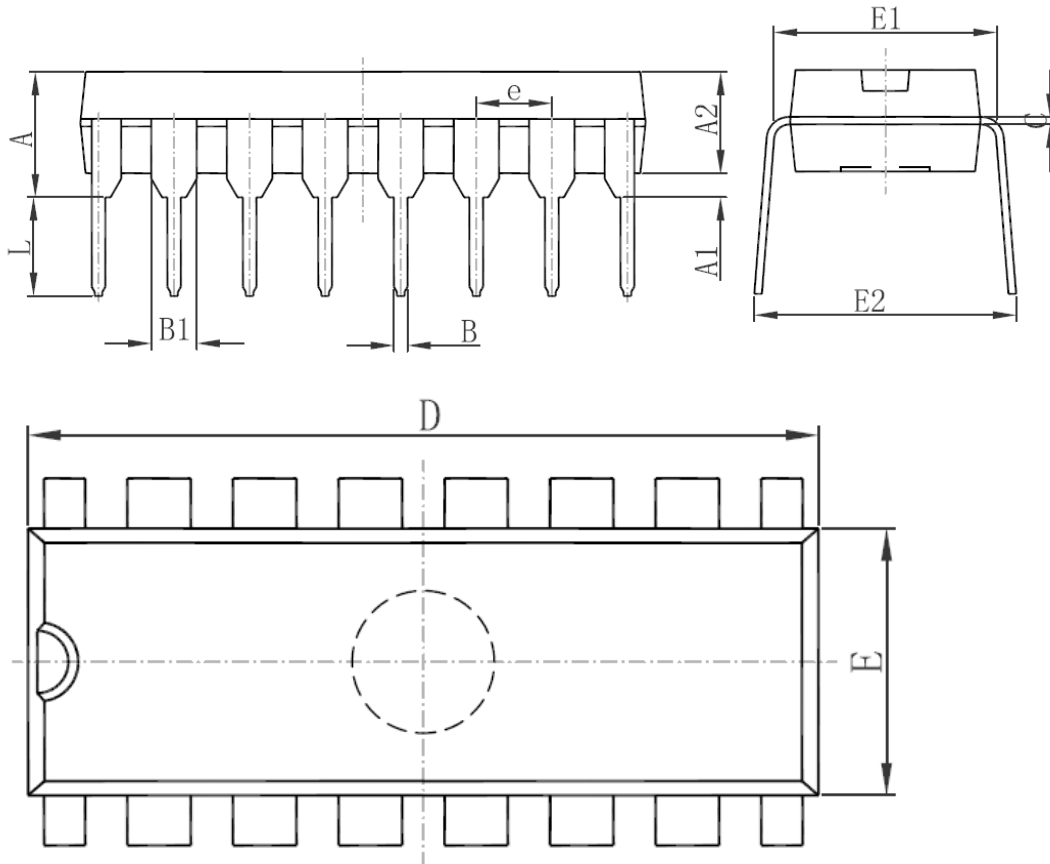

Fig. 9 Latch-Up Test Circuit and Voltage Waveform

- Notes:
- 8. The pulse generator has the following characteristics:
Pulse Width=12.5Hz, output impedance 50Ω, $t_r \leq 5\text{ns}$, $t_f \leq 10\text{ns}$.
 - 9. C_L includes probe and jig capacitance.
 - 10. $V_{IH} = 3\text{V}$

DIP-16 Outline Dimensions



Symbol	Dimensions In Millimeters		Dimensions In Inches	
	Min	Max	Min	Max
A	3.710	4.310	0.146	0.170
A1	0.510		0.020	
A2	3.200	3.600	0.126	0.142
B	0.380	0.570	0.015	0.022
B1	1.524 (BSC)		0.060 (BSC)	
C	0.204	0.360	0.008	0.014
D	18.800	19.200	0.740	0.756
E	6.200	6.600	0.244	0.260
E1	7.320	7.920	0.288	0.312
e	2.540 (BSC)		0.100 (BSC)	
L	3.000	3.600	0.118	0.142
E2	8.400	9.000	0.331	0.354

SOP-16 Outline Dimensions

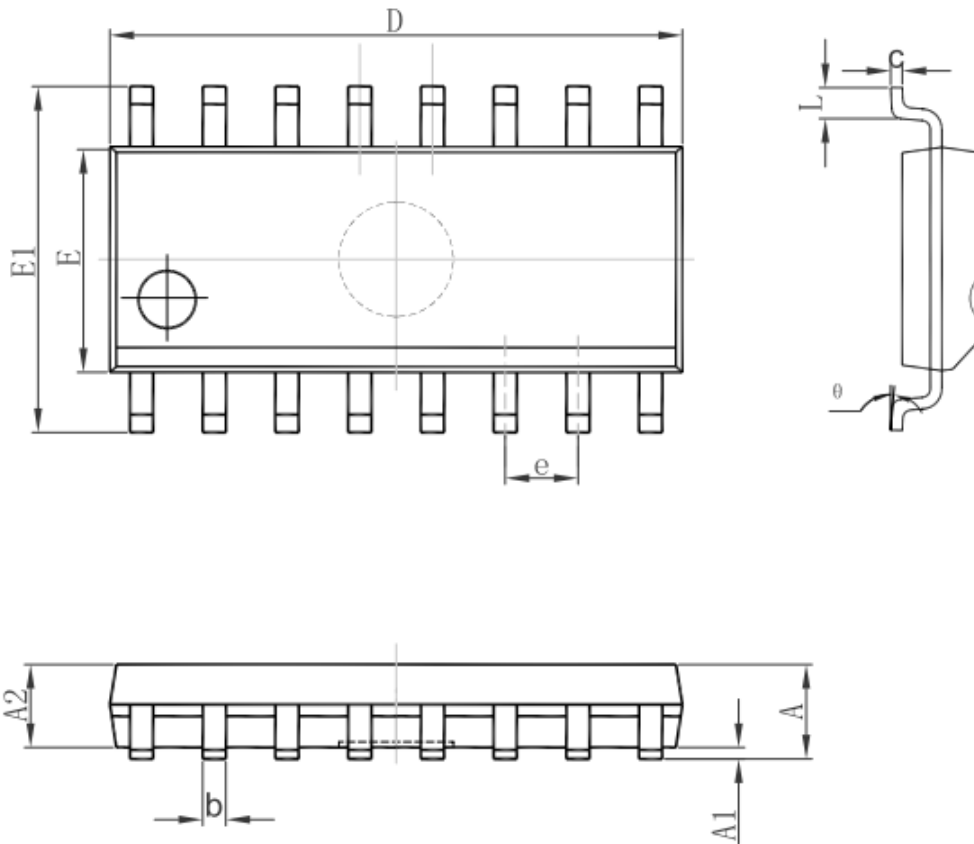

Symbol	Dimensions In Millimeters		Dimensions In Inches	
	Min	Max	Min	Max
A	1.350	1.750	0.053	0.069
A1	0.100	0.250	0.004	0.010
A2	1.350	1.550	0.053	0.061
b	0.330	0.510	0.013	0.020
c	0.170	0.250	0.007	0.010
D	9.800	10.200	0.386	0.402
E	3.800	4.000	0.150	0.157
E1	5.800	6.200	0.228	0.244
e	1.270 (BSC)		0.050 (BSC)	
L	0.400	1.270	0.016	0.050
θ	0°	8°	0°	8°

TSSOP16 Outline Dimensions

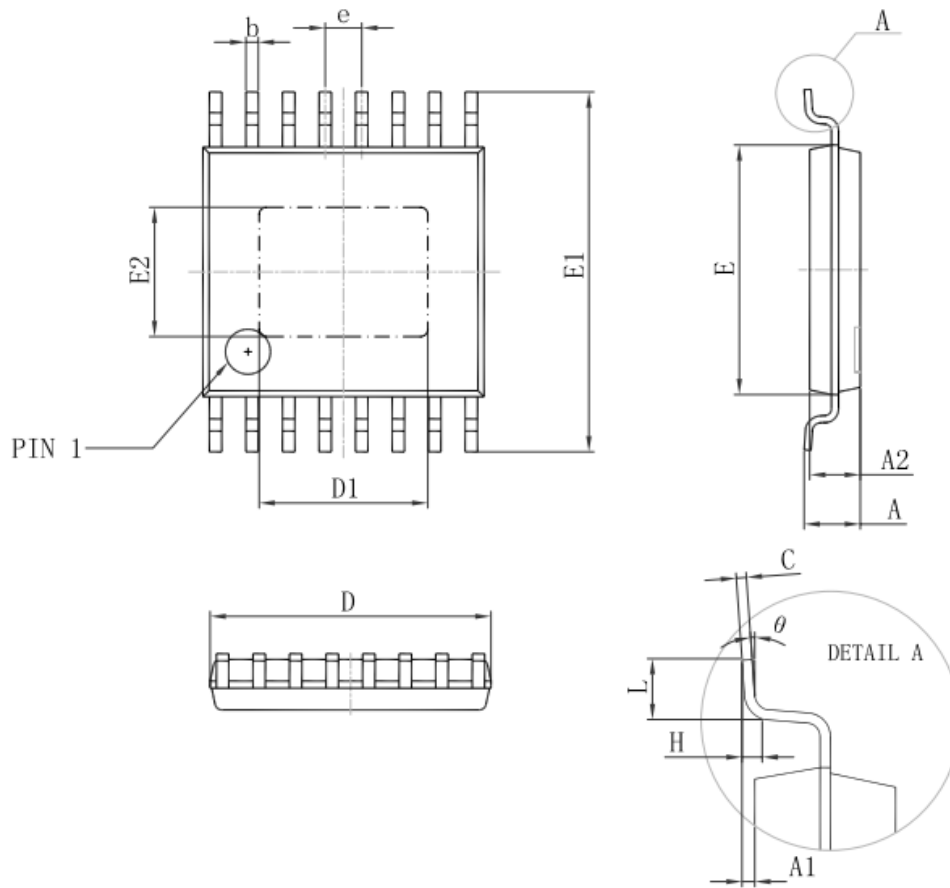

Symbol	Dimensions In Millimeters		Dimensions In Inches	
	Min	Max	Min	Max
D	4.900	5.100	0.193	0.201
D1	2.900	3.100	0.114	0.122
E	4.300	4.500	0.169	0.177
b	0.190	0.300	0.007	0.012
e	0.090	0.200	0.004	0.008
E1	6.250	6.550	0.246	0.258
E2	2.200	2.400	0.087	0.094
A		1.150		0.043
A2	0.800	1.000	0.031	0.039
A1	0.020	0.150	0.001	0.006
e	0.65 (BSC)		0.026 (BSC)	
L	0.500	0.700	0.02	0.028
H	0.25(TYP)		0.01(TYP)	
θ	1°	7°	1°	7°