

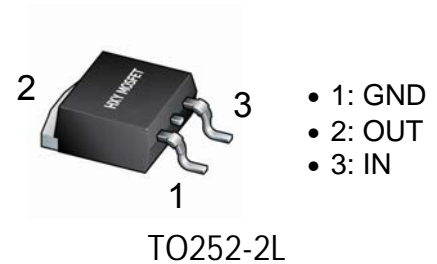

DESCRIPTION

The AMS1117CD is a three-terminal output current up to 1A Output low pressure difference linear regulator, 1.2V,1.8V,2.5V,3.3V,5.0V and adjustable output voltage and other versions, Its voltage drop is only 1.2V at 1A.

With its excellent nature Energy and extreme economic performance, suitable fo all kinds of electrical production Product.



FEATURES:

- The voltage drop of 1A output current is 1.2V
- Current limiting function
- Overheat protection
- Fixed output voltage 1.2V, 1.8V, 2.5V, 3.3V, 5.0V and adjustable output voltage version
- The voltage accuracy is 2% with a fixed output voltage of 1.2V
- Fixed output voltage 1.8V, 2.5V, 3.3V, 5.0V And adjustable output voltage accuracy is 1.5%
- Temperature range: -40 ° C to +125 ° C

APPLICATION :

- Palm pilots and laptops
- Battery chargers
- SCSI-ii Active terminal
- mobile telephone
- Battery supply system
- Switching power supply rear voltage regulator

Absolute Maximum ratings

Parameter	Symbol	Value	Unit
Input Voltage	Vin	18	V
Pin temperature (welding 5 seconds)	Tlead	260	°C
Working junction temperature range	Tj	150	°C
ESD capability (minimum)	ESD	2000	V
Power Dissipation	PD	Note1	mW
Operating Junction Temperature Range	TOPR	-40~+125	°C
Storage Temperature Range	TSTG	-65~+150	°C

Note1: Maximum permissible power consumption is a function of the maximum operating junction temperature Tj(Max), pair air thermal resistance and ambient temperature. Maximum permissible power consumption At a given ambient temperature, exceeding the maximum allowable power consumption will cause the chip temperature to be too high, and the regulator will therefore enter overheat protection State. The pair air thermal resistance of different packaging types is different, depending on the packaging technology.



Typical application circuit

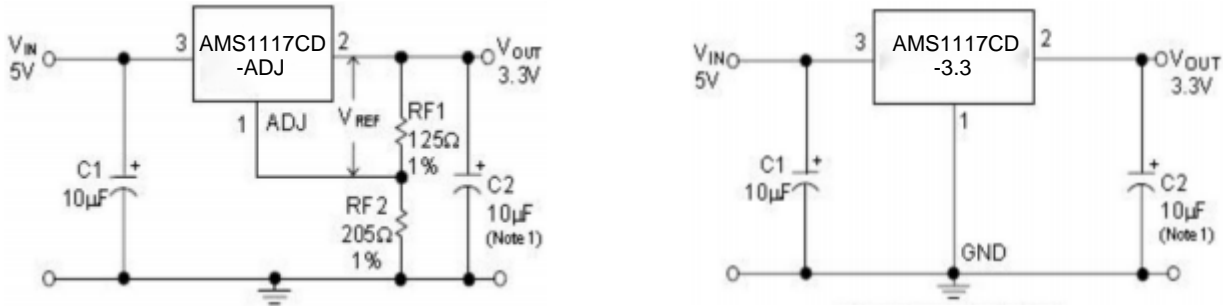

$$V_{ref} = V_{out} - V_{adj} = 1.25V \text{ (typical value)}$$

$$V_{out} = V_{ref} * (1 + RF2/RF1) + I_{adj} * RF2$$

$$I_{adj} = 55\mu A \text{ (typical value)}$$

The internal block diagram :

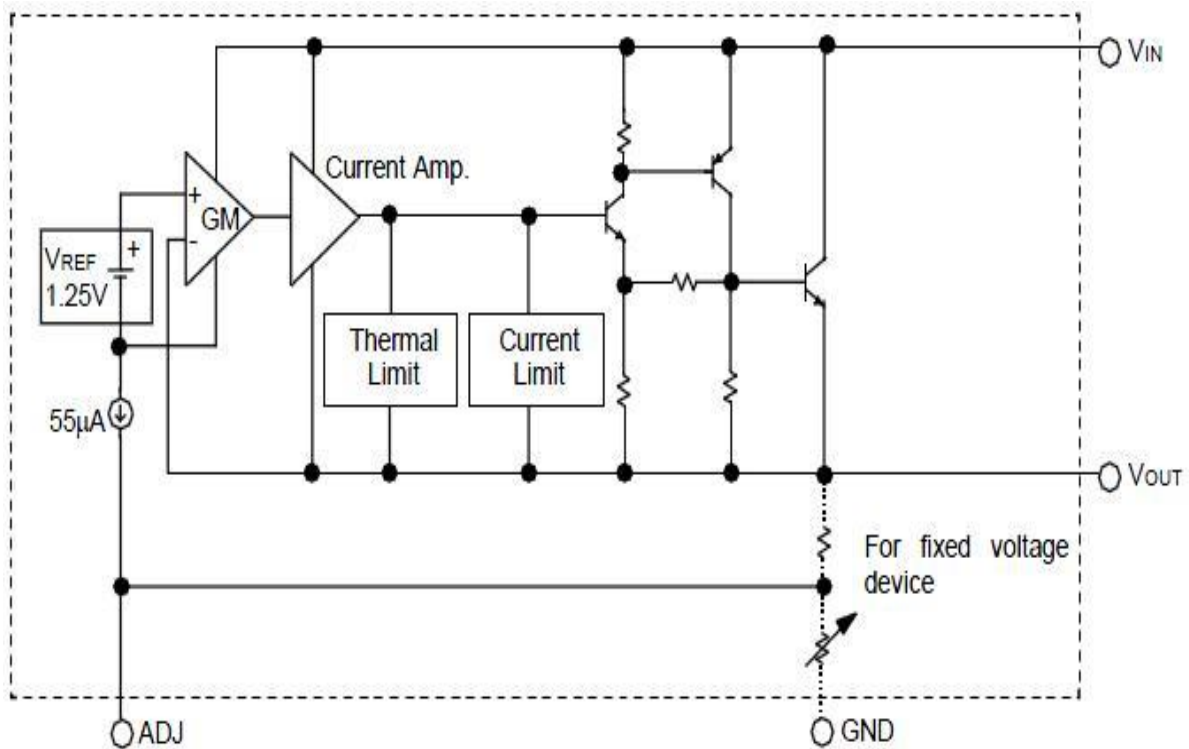

Recommended working conditions :

Parameter	Symbol	Value	Unit
Input Voltage	V _{in}	12	V
Working junction temperature range	T _j	-40~+125	°C



ELECTRICAL CHARACTERISTICS

(Tamb=25°C, normal junction temperature range -40~+125°C unless otherwise specified)

Parameter	Symbol	Test Condition	Min	Typ	Max	Unit
reference voltage	Vref	AMS1117-ADJ, IOUT=10mA, VIN-VOUT=2V, TJ=25°C 10mA≤IOUT≤1A, 1.4V≤VIN-VOUT≤10V	1.231 1.225	1.250 1.250	1.268 1.275	V
Output Voltage	VOUT	AMS1117-1.2, IOUT=10mA, VIN=3.2V, TJ=25°C 10mA≤ IOUT≤1A, 3.0V≤VIN≤10V	1.176 1.152	1.200 1.200	1.224 1.248	V
		AMS1117-1.5, IOUT=10mA, VIN=3.5V, TJ=25°C 10mA≤ IOUT≤1A, 3.0V≤VIN≤10V	1.477 1.470	1.500 1.500	1.522 1.530	V
		AMS1117-1.8, IOUT=10mA, VIN=3.8V, TJ=25°C, 0≤IOUT≤1A, 3.2V≤VIN≤10V	1.773 1.746	1.800 1.800	1.827 1.854	V
		AMS1117-2.5, IOUT=10mA, VIN=4.5V, TJ=25°C, 0≤IOUT≤1A, 3.9V≤VIN≤ 10V	2.462 2.450	2.500 2.500	2.538 2.550	V
		AMS1117-3.3, IOUT=10mA, VIN=5V, TJ=25°C, 0≤IOUT≤ 1A, 4.75V≤VIN≤10V	3.250 3.235	3.300 3.300	3.349 3.365	V
		AMS1117-5.0, IOUT=10mA, VIN=7V, TJ=25°C, 0≤ IOUT≤1A, 6.5V≤VIN≤12V	4.925 4.900	5.000 5.000	5.075 5.100	V
Temperature stability of output voltage	TSout			0.3		%
linearity control	Rline	VINMIN ≤VIN≤ 12V, VOUT=Fixed/Adj, Iout=10mA		6	15	mV
load regulation	Rload	10mA≤IOUT≤1A, VOUT=Fixed/Adj		6	18	mV
differential pressure	Vdrop	IOUT=100mA		1.00	1.20	V
		IOUT=500mA		1.05	1.25	
		IOUT=1A		1.20	1.30	



ELECTRICAL CHARACTERISTICS

(Tamb=25°C, normal junction temperature range -40~+125°C unless otherwise specified)

Parameter	Symbol	Test Condition	Min	Typ	Max	Unit
quiescent current	I_q	4.25V≤VIN≤6.5V		5	10	mA
Ripple rejection ratio	PSRR	f _{RIPPLE} =120Hz, (VIN-VOUT)=3V, V _{RIPPLE} =1VPP	50	60		dB
Adjustable current	I_{adj}			60	120	μA
Adjustable pin current change		0≤I _{OUT} ≤800mA, 1.4V ≤VIN-VOUT≤10V		0.2	5	μA
Temperature protection	TSD			150		°C
current-limiting protection	I_{limit}		1.4	1.6	1.8	A
temperature stability				0.5		%
RMS output noise		% of V _{OUT} , 10Hz≤f≤10kHz		0.005		%
Thermal resistance coefficient (No heat sink)		SOT-223-3L		120		°C/W
		TO-252-2L		100		



Typical Performance Characteristics

Dropout Voltage vs. Output Current

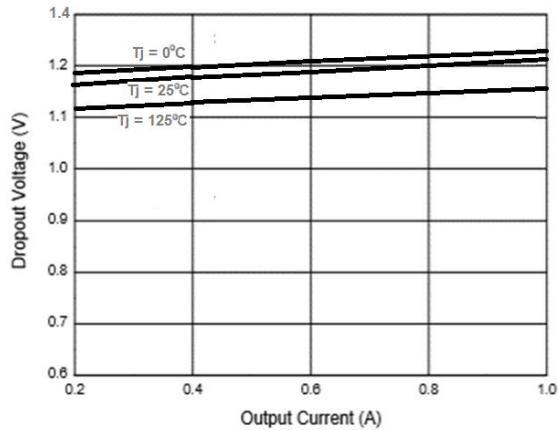

Dropout Voltage vs. Junction Temperature

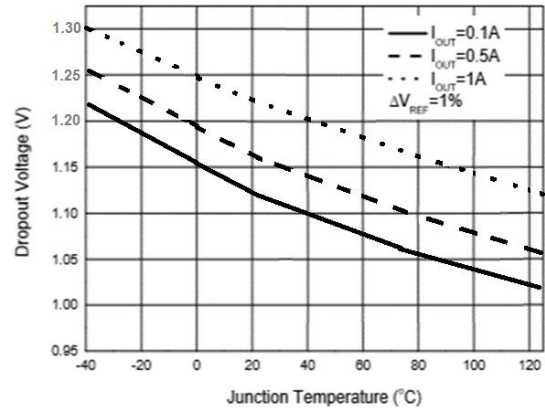

Load Regulation vs. Junction Temperature

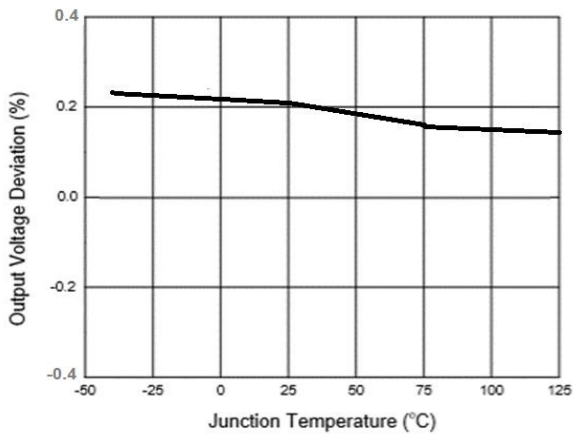

Reference Voltage vs. Junction Temperature

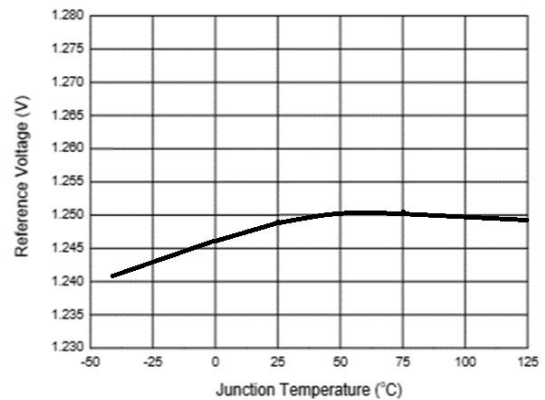

Output Voltage vs. Junction Temperature

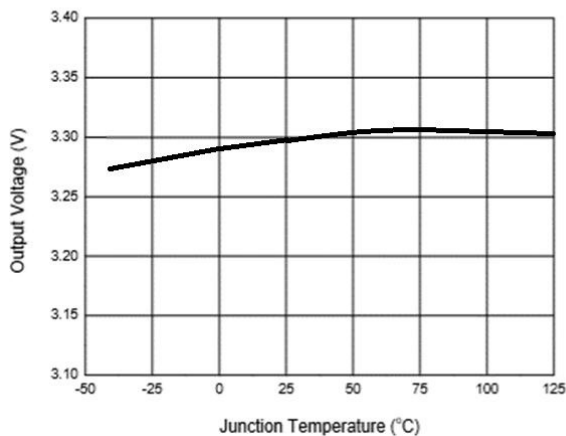

Minimum Load Current vs. Junction Temperature

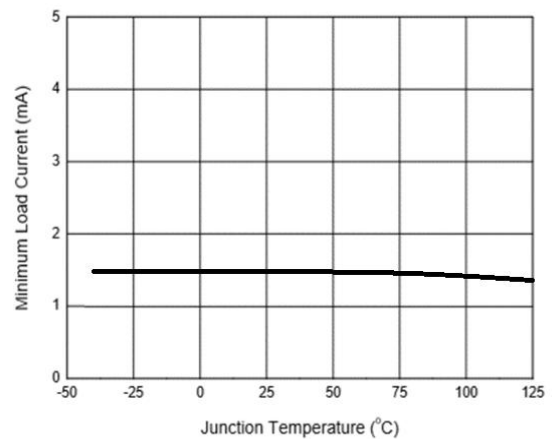



Adjust Pin Current vs. Junction Temperature

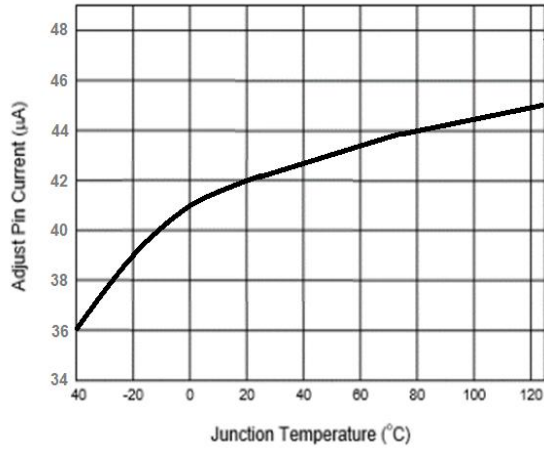

Short-circuit Current vs. Junction Temperature

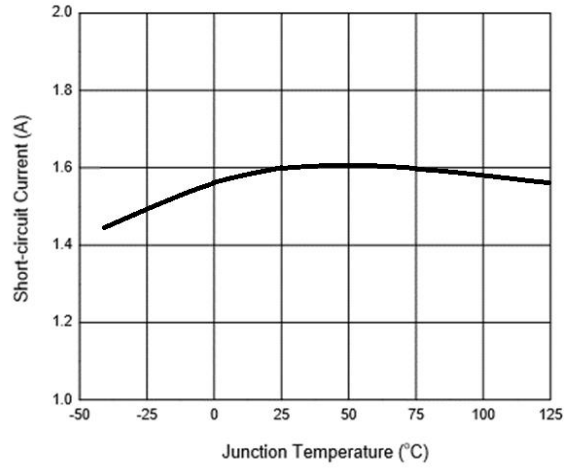

Ripple Rejection vs. Frequency

$V_{in}=V_{out}+2.5\text{ V}$, $I_{out}=100\text{ mA}$, $C_{out}=10\mu\text{F}$

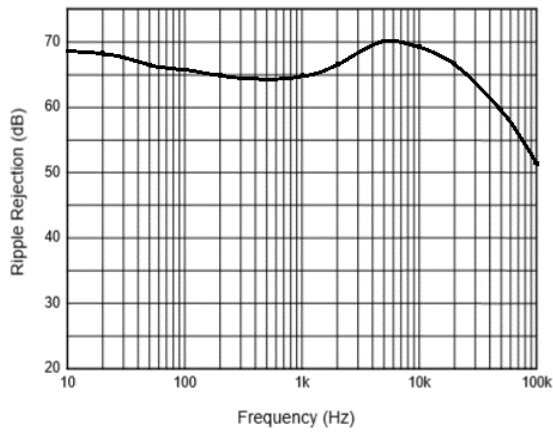



TO-252-2L Package Information

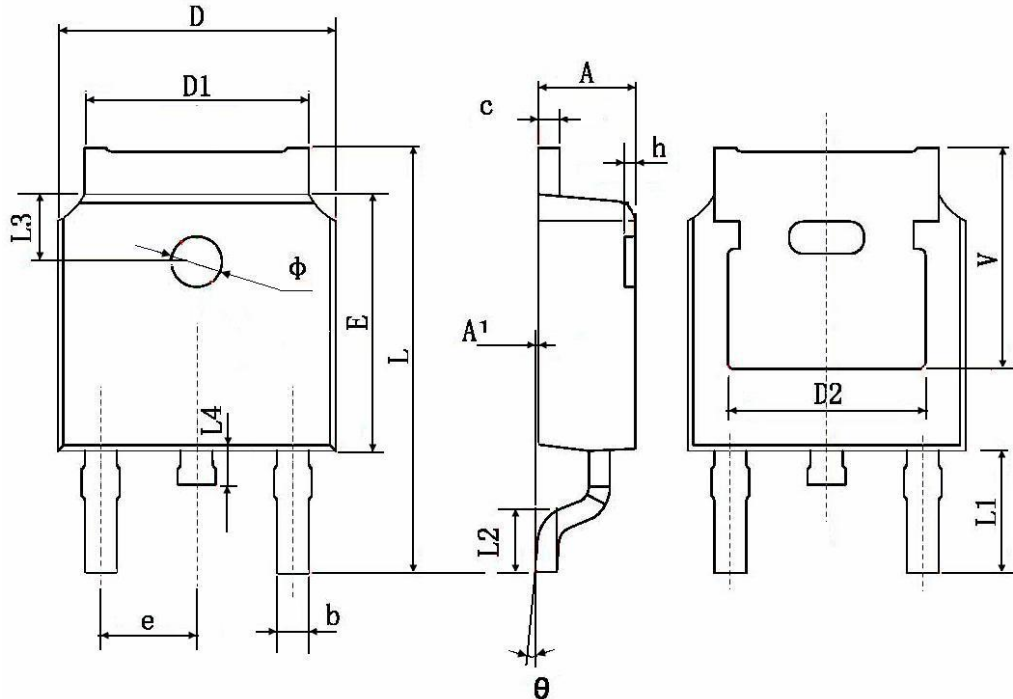

Symbol	Dimensions In Millimeters		Dimensions In Inches	
	Min.	Max.	Min.	Max.
A	2.200	2.400	0.087	0.094
A1	0.000	0.127	0.000	0.005
b	0.660	0.860	0.026	0.034
c	0.460	0.580	0.018	0.023
D	6.500	6.700	0.256	0.264
D1	5.100	5.460	0.201	0.215
D2	0.483 TYP.		0.190 TYP.	
E	6.000	6.200	0.236	0.244
e	2.186	2.386	0.086	0.094
L	9.800	10.400	0.386	0.409
L1	2.900 TYP.		0.114 TYP.	
L2	1.400	1.700	0.055	0.067
L3	1.600 TYP.		0.063 TYP.	
L4	0.600	1.000	0.024	0.039
φ	1.100	1.300	0.043	0.051
θ	0°	8°	0°	8°
h	0.000	0.300	0.000	0.012
V	5.350 TYP.		0.211 TYP.	



Attention

- Any and all HUA XUAN YANG ELECTRONICS products described or contained herein do not have specifications that can handle applications that require extremely high levels of reliability, such as life-support systems, aircraft's control systems, or other applications whose failure can be reasonably expected to result in serious physical and/or material damage. Consult with your HUA XUAN YANG ELECTRONICS representative nearest you before using any HUA XUAN YANG ELECTRONICS products described or contained herein in such applications.
- HUA XUAN YANG ELECTRONICS assumes no responsibility for equipment failures that result from using products at values that exceed, even momentarily, rated values (such as maximum ratings, operating condition ranges, or other parameters) listed in products specifications of any and all HUA XUAN YANG ELECTRONICS products described or contained herein.
- Specifications of any and all HUA XUAN YANG ELECTRONICS products described or contained herein stipulate the performance, characteristics, and functions of the described products in the independent state, and are not guarantees of the performance, characteristics, and functions of the described products as mounted in the customer's products or equipment. To verify symptoms and states that cannot be evaluated in an independent device, the customer should always evaluate and test devices mounted in the customer's products or equipment.
- HUA XUAN YANG ELECTRONICS CO.,LTD. strives to supply high-quality high-reliability products. However, any and all semiconductor products fail with some probability. It is possible that these probabilistic failures could give rise to accidents or events that could endanger human lives, that could give rise to smoke or fire, or that could cause damage to other property. When designing equipment, adopt safety measures so that these kinds of accidents or events cannot occur. Such measures include but are not limited to protective circuits and error prevention circuits for safe design, redundant design, and structural design.
- In the event that any or all HUA XUAN YANG ELECTRONICS products(including technical data, services) described or contained herein are controlled under any of applicable local export control laws and regulations, such products must not be exported without obtaining the export license from the authorities concerned in accordance with the above law.
- No part of this publication may be reproduced or transmitted in any form or by any means, electronic or mechanical, including photocopying and recording, or any information storage or retrieval system, or otherwise, without the prior written permission of HUA XUAN YANG ELECTRONICS CO.,LTD.
- Information (including circuit diagrams and circuit parameters) herein is for example only ; it is not guaranteed for volume production. HUA XUAN YANG ELECTRONICS believes information herein is accurate and reliable, but no guarantees are made or implied regarding its use or any infringements of intellectual property rights or other rights of third parties.
- Any and all information described or contained herein are subject to change without notice due to product/technology improvement, etc. When designing equipment, refer to the "Delivery Specification" for the HUA XUAN YANG ELECTRONICS product that you intend to use.