

Main

Range of product	Twido
Product or component type	Modular base controller
Discrete I/O number	20
Discrete input number	12
Discrete input logic	Sink or source
Discrete input voltage	24 V
Discrete input voltage type	DC
Discrete output number	2 transistor (source) 6 relay
[Us] rated supply voltage	24 V DC
Number of I/O expansion module 7	
Free slots	2
Use of slot	32 K or 64 K memory cartridge and 1 realtime clock

Complementary

Input voltage limits	20.4...26.4 V
Discrete input current	5 mA for I0.0 to I0.1 5 mA for I0.6 to I0.7 7 mA for I0.2 to I0.5 7 mA for I0.8 to I0.11
Input impedance	4700 Ohm for I0.2 to I0.5 4700 Ohm for I0.8 to I0.11 5700 Ohm for I0.0 to I0.1 5700 Ohm for I0.6 to I0.7
Filter time	150 µs for I0.2 to I0.5 at state 0 150 µs for I0.8 to I0.11 at state 0 35 µs for I0.0 to I0.1 at state 1 35 µs for I0.6 to I0.7 at state 1 40 µs for I0.2 to I0.5 at state 1 40 µs for I0.8 to I0.11 at state 1 45 µs for I0.0 to I0.1 at state 0 45 µs for I0.6 to I0.7 at state 0
Insulation between channel and internal logic	1500 Vrms for 1 minute
Insulation resistance between channel	None
Discrete output voltage	24 V
Output voltage limits	20.4...28.8 V
Current per channel	2 A for relay output 0.36 A for transistor output
Current per output common	1 A for transistor output 8 A for relay output
Response time	5 µs for Q0.0 to Q0.1 at state 0 5 µs for Q0.0 to Q0.1 at state 1
[Ures] residual voltage	<= 1 V at state 1
Leakage current	0.1 mA
Output overvoltage protection	39 V
Tungsten load	8 W
Surge current	<= 5 A for relay output
Discrete output current	300 mA
Minimum load	0.1 mA
Contact resistance	<= 40000 µOhm
Load current	2 A at 240 V AC inductive load, operating rate = 30 cyc/mn for relay output 2 A at 240 V AC resistive load, operating rate = 30 cyc/mn for relay output 2 A at 30 V DC inductive load, operating rate = 30 cyc/mn for relay output

The information provided in this documentation contains general descriptions and/or technical characteristics of the products contained herein. This documentation is not intended as a substitute for and is not to be used for determining suitability or reliability of these products for specific user applications. It is the duty of any such user or integrator to perform the appropriate and complete risk analysis, evaluation and testing of the products with respect to the relevant specific application or use thereof. Neither Schneider Electric Industries SAS nor any of its affiliates or subsidiaries shall be responsible or liable for misuse of the information contained herein.

	2 A at 30 V DC resistive load, operating rate = 30 cyc/mn for relay output
Mechanical durability	>= 20000000 cycles relay output
Electrical durability	>= 100000 cycles for relay output
Current consumption	30 mA at 5 V DC at state 1 40 mA at 24 V DC at state 1 5 mA at 5 V DC at state 0
I/O connection	Removable screw terminal block
Input/output number	<= 132, removable screw terminal block with I/O expansion module <= 188, spring terminal block with I/O expansion module <= 244, HE-10 connector with I/O expansion module
Supply voltage limits	20.4...26.4 V
Protection type	Power protection with internal fuse
Power consumption in W	<= 19 W (base + 4 expansion module)
Inrush current	<= 1 A for transistor output <= 50 A for power supply
Insulation resistance	> 10 MOhm at 500 V, between I/O and earth terminals > 10 MOhm at 500 V, between supply and earth terminals
Program memory	3000 instructions 6000 instructions with 64 K memory cartridge
Exact time for 1 Kinstruction	1 ms
System overhead	0.5 ms
Memory description	Internal RAM, 128 counters, no floating, no trigonometrical Internal RAM, 128 timers, no floating, no trigonometrical Internal RAM, 256 internal bits, no floating, no trigonometrical Internal RAM, 3000 internal words, no floating, no trigonometrical Internal RAM, double words, no floating, no trigonometrical Internal RAM, floating, trigonometrical
Battery type	Lithium for internal RAM, autonomy: 30 days, charging time = 15 h, battery life = 10 yr
Integrated connection type	Power supply Non isolated serial link mini DIN, Modbus/character mode master/slave RTU/ASCII (RS485) half duplex, 38,4 kbit/s
Counting input number	2 channel(s) at 20000 Hz 32 bits 2 channel(s) at 5000 Hz 16 bits
Positioning functions	PWM/PLS 2 channel(s) at 7 kHz
Analogue input number	1
Analogue input range	0...10 V
Analogue input resolution	9 bits
Input impedance	100000 Ohm
Complementary function	Event processing PID
Analogue adjustment points	1 point adjustable from 0...1023
Status LED	1 LED ERR 1 LED STAT 1 LED green PWR 1 LED green RUN 1 LED per channel I/O status
CAD overall width	1.89 in (48 mm)
CAD overall height	3.74 in (95 mm)
CAD overall depth	2.76 in (70 mm)
Terminals description PLC n°1	(0)IN_DIS#0 (1)IN_DIS#1 (10)IN_DIS#10 (11)IN_DIS#11 (2)IN_DIS#2 (3)IN_DIS#3 (4)IN_DIS#4 (5)IN_DIS#5 (6)IN_DIS#6 (7)IN_DIS#7 (8)IN_DIS#8 (9)IN_DIS#9 (COM)COM_NEG#0-11 ALT TB_1
Terminals description PLC n°2	(0)IN_DIS#0 (1)IN_DIS#1

(10)IN_DIS#10
 (11)IN_DIS#11
 (2)IN_DIS#2
 (3)IN_DIS#3
 (4)IN_DIS#4
 (5)IN_DIS#5
 (6)IN_DIS#6
 (7)IN_DIS#7
 (8)IN_DIS#8
 (9)IN_DIS#9
 (COM)COM_POS#0-11
 ALT_1
 TB_1

Terminals description PLC n°3	(0)OUT_DIS#0 (1)OUT_DIS#1 (2)OUT_DIS#2 (3)OUT_DIS#3 (4)OUT_DIS#4 (5)OUT_DIS#5 (6)OUT_DIS#6 (7)OUT_DIS#7 (COM0)COM0_POS#0-1 (COM1)COM1#2-4 (COM2)COM2#5-6 (COM3)COM3#7 (NC)UNUSED (V-)PW_NEG TB_2
Product weight	0.41 lb(US) (0.185 kg)

Environment

immunity to microbreaks	10 ms
dielectric strength	1500 V for 1 minute, between I/O and earth terminals 500 V for 1 minute, between supply and earth terminals
product certifications	CSA UL
marking	CE
ambient air temperature for storage	-13...158 °F (-25...70 °C)
ambient air temperature for operation	32...131 °F (0...55 °C)
relative humidity	30...95 % without condensation
IP degree of protection	IP20
operating altitude	0...6561.68 ft (0...2000 m)
storage altitude	0...9842.52 ft (0...3000 m)
vibration resistance	0.075 mm, 10...57 Hz mounting on: 35 mm symmetrical DIN rail 1 gn, 57...150 Hz mounting on: 35 mm symmetrical DIN rail 1.6 mm, 2...25 Hz mounting on: plate or panel with fixing kit 4 gn, 25...100 Hz mounting on: plate or panel with fixing kit
shock resistance	15 gn 11 ms

Contractual warranty

Warranty period	18 months
-----------------	-----------

Dimensions

mm
in.

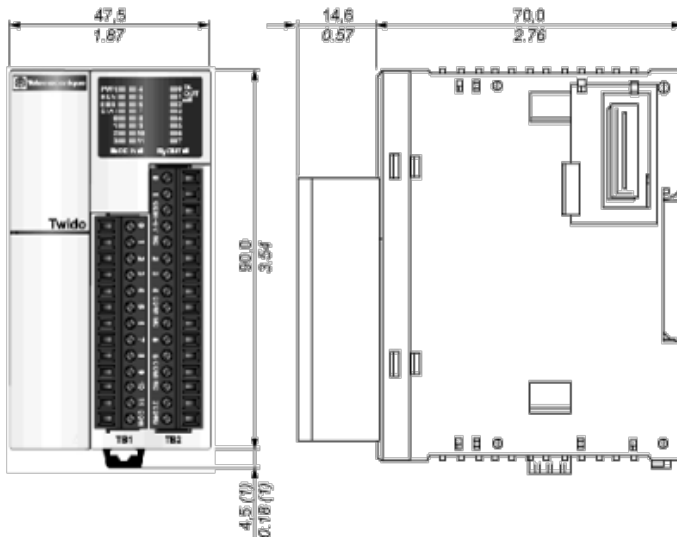

(1) 8.5 mm (0.33 in) when the clamp is pulled out.

Minimum Clearances for a Modular Base and Expansion I/O Modules

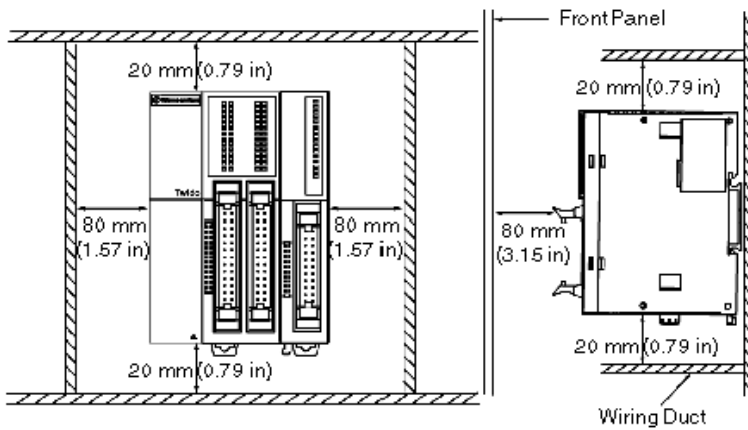

Mounting Hole Layout

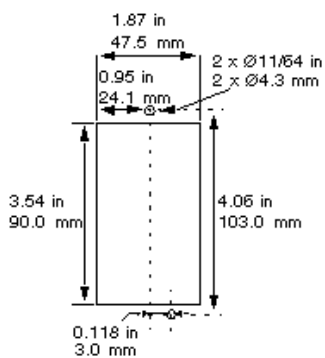

DC Power Supply Wiring

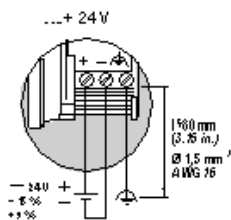

Wiring Diagram

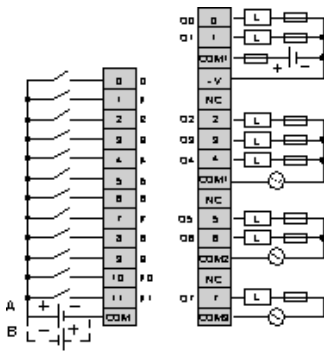

- A Positive logic.
- B Negative logic.

Performance Curves

I/O Usage Limits

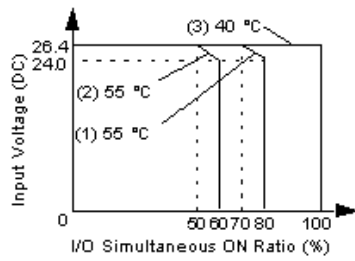

- (1) Limit for TWDLMDA20DUK and TWDLMDA20DTK
- (2) Limit for TWDLMDA40DUK and TWDLMDA40DTK
- (3) All modular bases

Mouser Electronics

Authorized Distributor

Click to View Pricing, Inventory, Delivery & Lifecycle Information:

[Schneider Electric:](#)

[TWDLMDA20DRT](#)