

SF-ASD 16/ACCU 2,0 AH - Battery module



1314530

<https://www.phoenixcontact.com/us/products/1314530>

Please be informed that the data shown in this PDF document is generated from our online catalog. Please find the complete data in the user documentation. Our general terms of use for downloads are valid.

Replacement battery, 2.0 Ah, lithium-ion, 3.6 V, for SF-ASD 16 cordless screwdriver



Your advantages

- Reverse polarity protected
- 3.6 V

Commercial data

Item number	1314530
Packing unit	1 pc
Minimum order quantity	1 pc
Sales key	BH32
Product key	BH324Y
GTIN	4063151579005
Weight per piece (including packing)	111.3 g
Weight per piece (excluding packing)	111.3 g
Customs tariff number	85076000
Country of origin	TW

SF-ASD 16/ACCU 2,0 AH - Battery module



1314530

<https://www.phoenixcontact.com/us/products/1314530>

Technical data

Notes

General	packed in cardboard
---------	---------------------

Product properties

Product type	Battery module
Type of packaging	packed in cardboard
Battery-operated voltage	3.6 V
Battery charging	60 min.

Insulation characteristics

Protection class	II
------------------	----

Electrical properties

Power consumption	7.2 W
Nominal voltage U_N	3.6 V DC
	3.6 V DC

Battery

Battery charging	60.00 min.
Battery-operated voltage	3.60 V DC
Battery capacity	2.00 Ah

Dimensions

Length	82 mm
Diameter	43 mm

Material specifications

Color	multicolored
-------	--------------

Environmental and real-life conditions

Ambient conditions

Ambient temperature (operation)	5 °C ... 40 °C
Ambient temperature (storage/transport)	-25 °C ... 60 °C
Permissible humidity (operation)	95 % (<)

Mounting

Thread type	()
-------------	----

Drawings

Schematic diagram

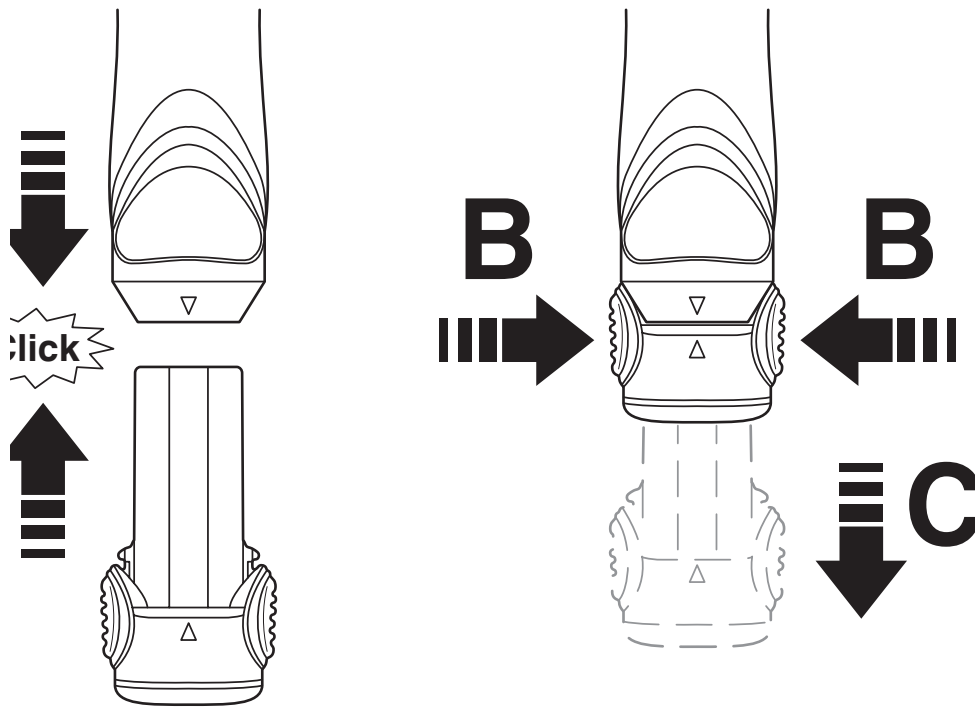

Schematic diagram

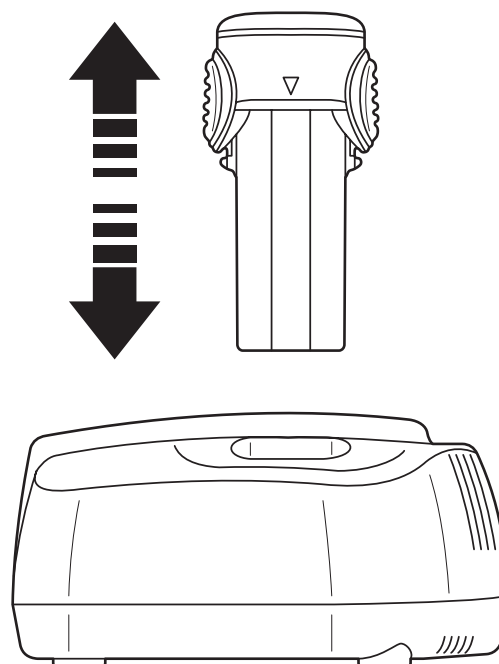

SF-ASD 16/ACCU 2,0 AH - Battery module



1314530

<https://www.phoenixcontact.com/us/products/1314530>

Approvals

To download certificates, visit the product detail page: <https://www.phoenixcontact.com/us/products/1314530>



EAC

Approval ID: RU C-DE.AI30.B.01750

SF-ASD 16/ACCU 2,0 AH - Battery module



1314530

<https://www.phoenixcontact.com/us/products/1314530>

Classifications

ECLASS

ECLASS-11.0	21052902
ECLASS-12.0	21052902
ECLASS-13.0	21052902

ETIM

ETIM 9.0	EC001199
----------	----------

UNSPSC

UNSPSC 21.0	26111700
-------------	----------

SF-ASD 16/ACCU 2,0 AH - Battery module



1314530

<https://www.phoenixcontact.com/us/products/1314530>

Environmental product compliance

EU RoHS

Fulfills EU RoHS substance requirements	Not applicable, No electrical and electronic equipment (EEE), cannot be used in EEE
---	---

China RoHS

Environment friendly use period (EFUP)	EFUP-5
	An article-related China RoHS declaration table can be found in the download area for the respective article under "Manufacturer declaration". For all articles with EFUP-E, no China RoHS declaration table issued and required.

EU REACH SVHC

REACH candidate substance (CAS No.)	No substance above 0.1 wt%
-------------------------------------	----------------------------

SF-ASD 16/ACCU 2,0 AH - Battery module



1314530

<https://www.phoenixcontact.com/us/products/1314530>

Accessories

SF-ASD 16 - Cordless screwdriver

1200294

<https://www.phoenixcontact.com/us/products/1200294>



Cordless screwdriver, incl. battery, two-speed gearbox, forward/reverse running and 16-stage clutch up to 450 rpm, hexagonal quick connection.

SF-ASD 16 SET - Battery-powered screwdriver set

1200295

<https://www.phoenixcontact.com/us/products/1200295>



Cordless screwdriver in case, incl. battery, charging device 100 ... 240 V, 2 bits, two-speed gearbox, forward/reverse running and 16-stage clutch up to 450 rpm, hexagonal fast connection.

SF-ASD 16/ACCU 2,0 AH - Battery module

1314530

<https://www.phoenixcontact.com/us/products/1314530>



SF-ASD 16/CHARGER - Charger

1200296

<https://www.phoenixcontact.com/us/products/1200296>

Charger, for 100 ... 240 V mains voltage, recognition of battery and parameter check, rapid charging, short-circuit resistant, polarized, operating mode display



Phoenix Contact 2024 © - all rights reserved

<https://www.phoenixcontact.com>

Phoenix Contact USA
586 Fulling Mill Road
Middletown, PA 17057, United States
(+717) 944-1300
info@phoenixcon.com