

7	8	9
标记 MARK	ECN编号/变更内容 ECN NO/DEFINITION	修改 REVISE
		日期 DATE
		核准 APPROVE

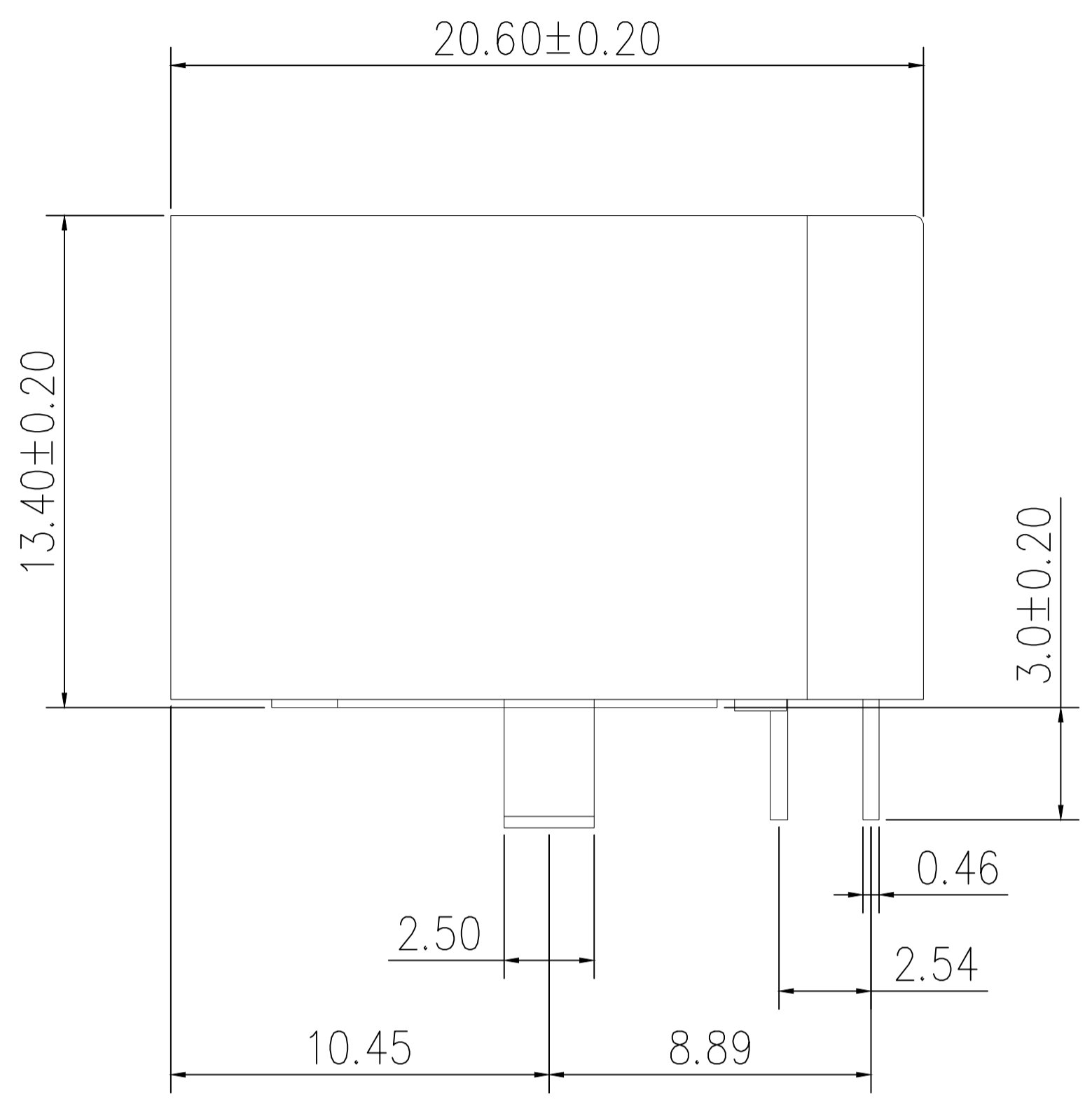

NOTES:
 1. MATERIAL:
 1.1.HOUSING: PBT ,COLOR IS BLACK;
 1.2.CONTACT: PHOSPHOR BRONZE, $\phi 0.46 \pm 0.02\text{mm}$;
 2.FINISH: PLATED OVER NI;
 3.RECINNEBDED PCB THICKNESS: 1.2~1.60mm;
 4.ELECTRICAL:
 4.1. VOLTAGE RATING: 125 VAC RMS;
 4.2. CURRENT RATING: 1.5 AMP;
 4.3. CONTACT RESISTANCE: 35MILLIOHMS MAX. ;
 4.4.WITHSTAND VOLTAGE: 1000 VAC RMS 50(60)Hz, 1MIN.;
 4.5.INSULATION RESISTANCE: 1000MEGOHMS MIN @500V DC.;
 5.MECHANICAL:
 5.1. MATING/UNMATING FORCE: 22N MAX.;
 5.2. RETENTION STRENGTH: 50N MIN.;
 5.3.OPERATING LIFE: 750 CYCLES MIN.;
 6.SALT SPRAY TEST: 12H;
 7.SOLDERABILITY: $245 \pm 5^\circ\text{C}, 5 \pm 0.5\text{S}$;
 RESISTANCE TOSOLDER: $260 + 5^\circ\text{C}, 10 + 1\text{S}$;
 ENVIRONMENTAL:
 9.1.STORAGE TEMPERATURE RANGE: $-40^\circ\text{C} \sim +85^\circ\text{C}$;
 9.2.OPERATION TEMPERATURE RANGE: $-25^\circ\text{C} \sim +70^\circ\text{C}$;

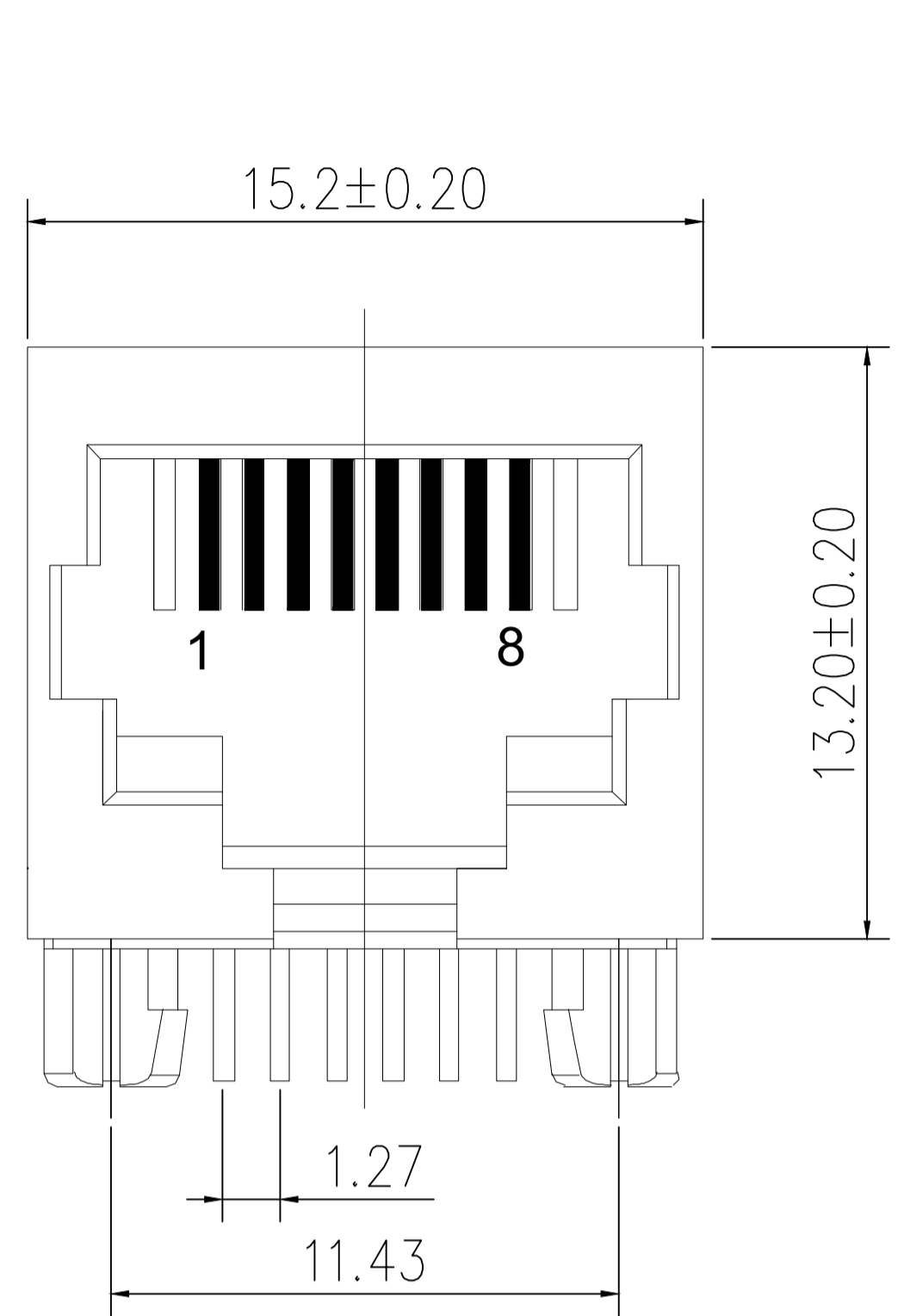
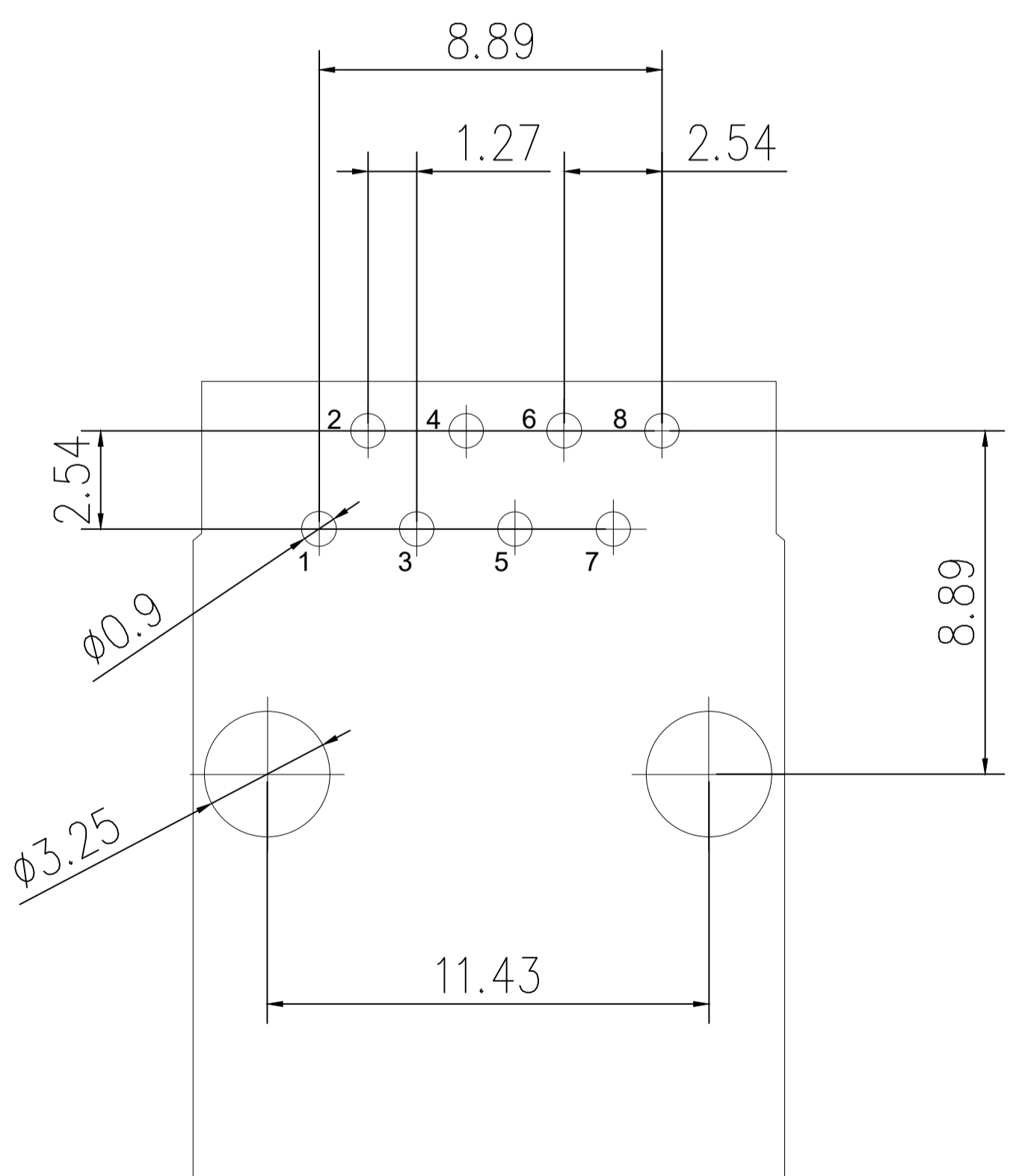
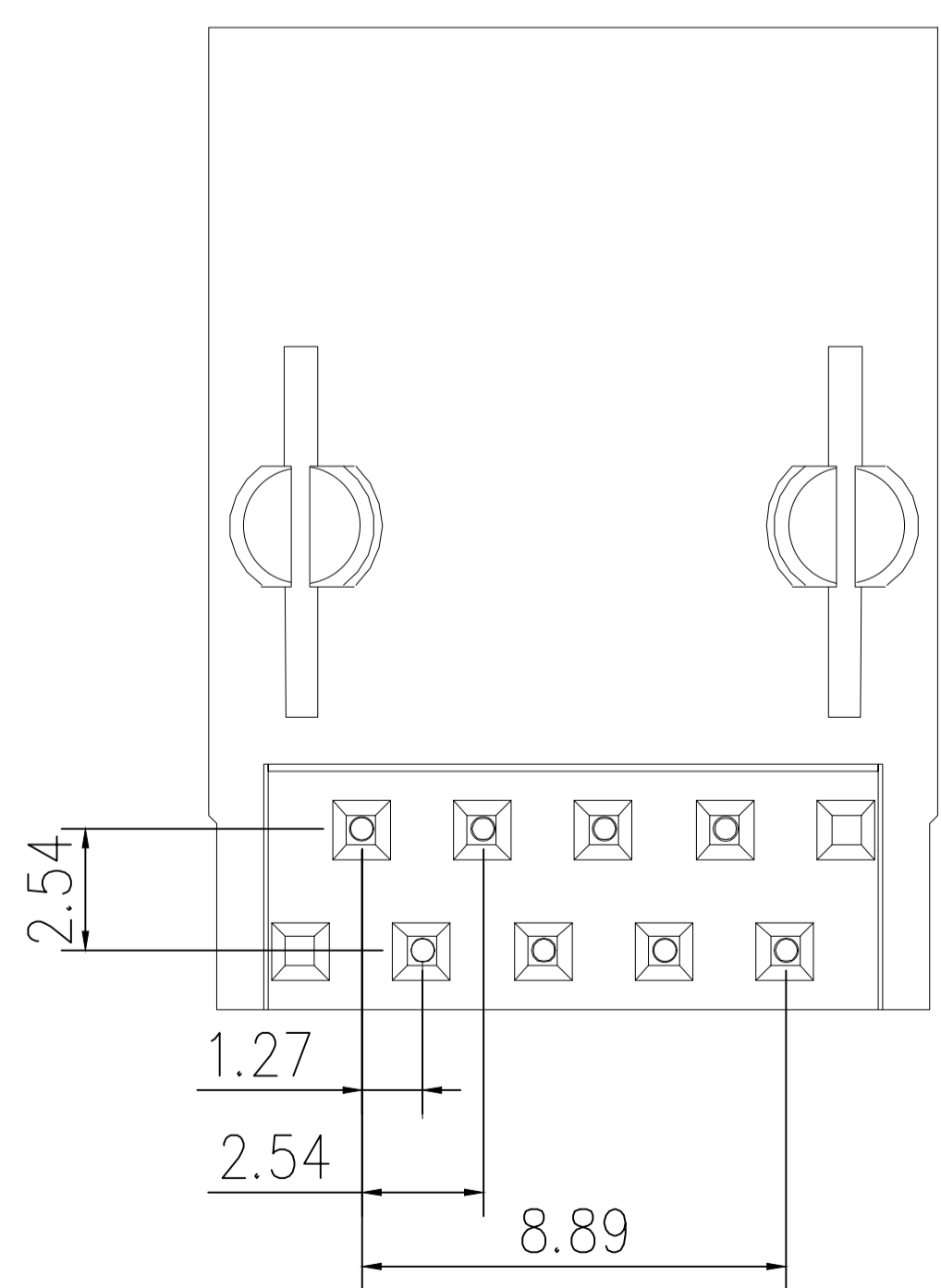

PCB LAYOUT
TOP VIEW

2	接触	铜	镀金	
1	基座	PBT	黑色	
序号	品名	材质	电镀/颜色	备注

深圳市虹成电子有限公司 GENERAL TOLERANCES (UNLESS SPECIFIED) X.xxx ±0.10 X.xx ±0.20 X.x ±0.30 X.xx° ±1° X.x° ±3° X.° ±5°	比列 SCALE	1:1	品名 TITLE	网口	
	单位 UNIT	MM	料号 PART NO	HC-WK88-H21-QS	
	张数 PART NO	1 OF 1	制图 DRAW	AhYe	
	版本 REV	A	审核 CHECKED	夏操云	
			批准 APPROVE	赵亮亮	