

REV.	DATE	BY-CHKD	REVISIONS	PART NUMBER	MATERIAL	FINISH			
R	29MAR2001	RJB/JGK	PRN: P2001-0035	82-47-104-15	STEEL	ZINC FLAKE COATING			
S	12APR2005	BRP/RLR	PRN: P2005-0589						

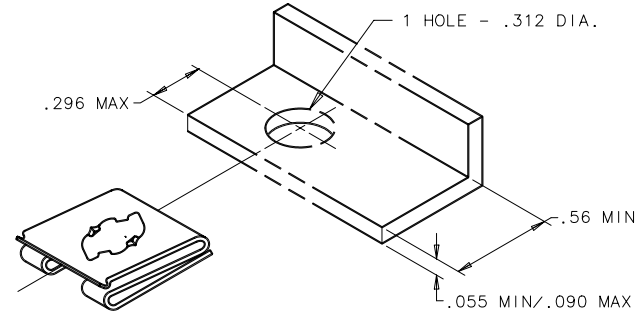
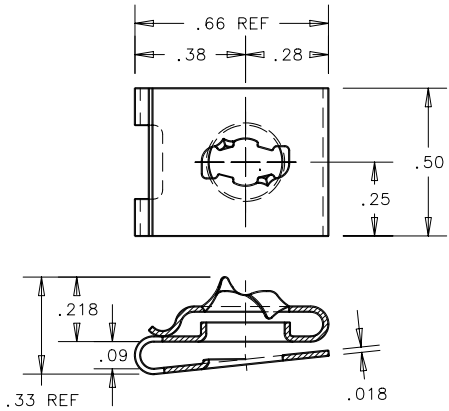

TO SELECT PROPER GRIP STUD FOR YOUR APPLICATION:

INSTALLATION EXAMPLE "A"

(WHEN "G" IS .033 OR LESS)

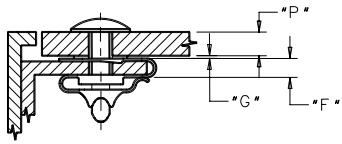

WHEN "G" IS .033 OR LESS, TOTAL MATERIAL THICKNESS (GRIP OF STUD) EQUALS; P+F+.050 (CONSTANT).

INSTALLATION EXAMPLE "B"

(WHEN "G" IS .034 OR GREATER)

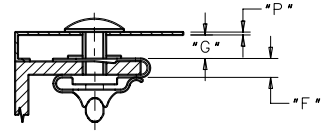

PAN TYPE PANELS

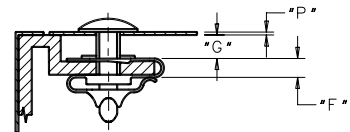

DIMPLED OR RECESSED PANELS

WHEN "G" IS .034 OR GREATER, TOTAL MATERIAL THICKNESS (GRIP OF STUD) EQUALS; P+F+G+.017 (CONSTANT).