

DESCRIPTION

The MP1917A is a high-frequency, half-bridge, N-channel power MOSFET driver. Its low-side and high-side driver channels are controlled independently and matched with less than 5ns of time delay. Under-voltage lockout (UVLO) on both the high-side and low-side supplies forces the outputs low in the event that the supply is insufficient. The integrated bootstrap diode reduces the external component count.

The MP1917A is available in a QFN-10 (4mmx4mm) package.

FEATURES

- Drives an N-Channel MOSFET Half-Bridge
- 115V Bootstrap Voltage Range
- On-Chip Bootstrap Diode
- Typical Propagation Delay of 20ns
- Gate Driver Matching of Less than 5ns
- Drives a 2.2nF Load with 15ns of Rise Time and 12ns of Fall Time at 12V VDD
- TTL-Compatible Input
- Quiescent Current of Less than 150µA
- UVLO for Both High-Side and Low-Side Gate Drivers
- QFN-10 (4mmx4mm) Package

APPLICATIONS

- Isolated Brick Power
- Telecom Half-Bridge Power Supplies
- Avionics DC/DC Converters
- Two-Switch Forward Converters
- Active Clamp Forward Converters

All MPS parts are lead-free, halogen free, and adhere to the RoHS directive. For MPS green status, please visit the MPS website under Quality Assurance. "MPS", the MPS logo, and "Simple, Easy Solutions" are registered trademarks of Monolithic Power Systems, Inc. or its subsidiaries.

TYPICAL APPLICATION

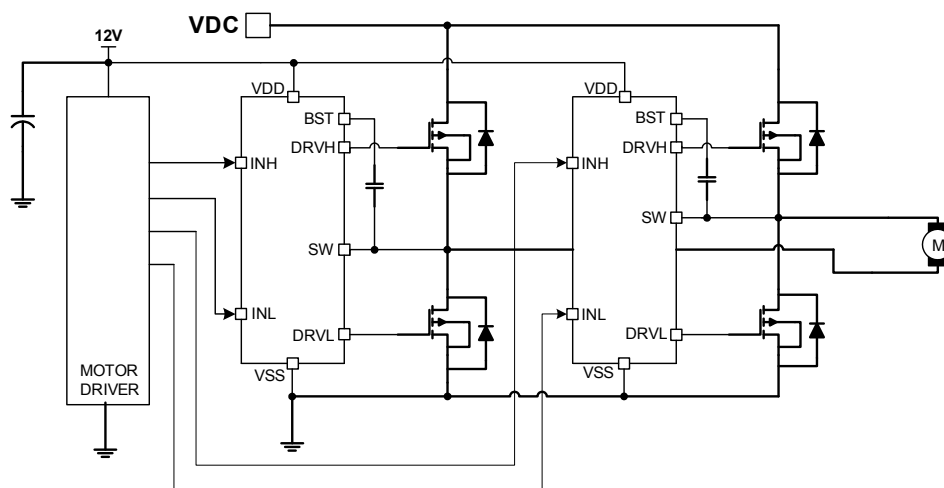

ORDERING INFORMATION

Part Number	Package	Top Marking
MP1917AGR*	QFN-10 (4mmx4mm)	See Below

* For Tape & Reel, add suffix -Z (e.g. MP1917AGR-Z).

TOP MARKING

MPSYWW

M1917A

LLLLLL

MPS: MPS prefix
 Y: Year code
 WW: Week code
 M1917A: First six digits of the part number
 LLL: Lot number

PACKAGE REFERENCE

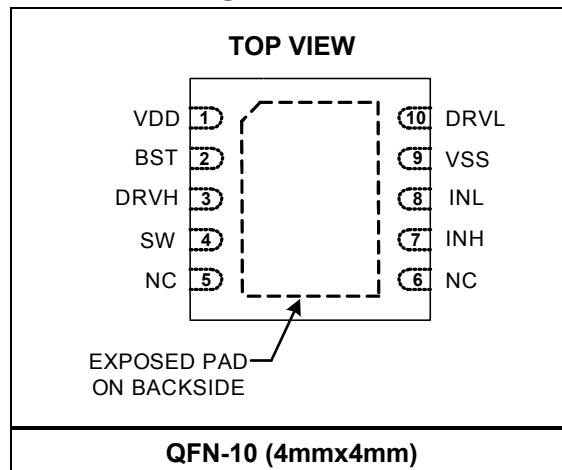

ABSOLUTE MAXIMUM RATINGS ⁽¹⁾

Supply voltage (V_{DD})	-0.3V to 18V
SW voltage (V_{SW})	-1V (-18V for < 100nS) to 105V
BST voltage (V_{BST})	-0.3V to 115V
BST to SW	-0.3V to 18V
DRVH to SW	-0.3V (-2V for < 100nS) to (BST - SW) + 0.3V
DRVL to VSS	-0.3V (-2V for < 100nS) to (V_{DD} + 0.3V)
All other pins	-0.3V to (V_{DD} + 0.3V)
Continuous power dissipation ($T_A = 25^\circ\text{C}$) ⁽²⁾	
QFN-10 (4mmx4mm)	2.66W
Junction temperature	150°C
Lead temperature	260°C
Storage temperature	-65°C to 150°C

Recommended Operating Conditions ⁽³⁾

Supply voltage (V_{DD})	8.0V to 15.0V
SW voltage (V_{SW})	-1.0V to 98V
SW slew rate	<50V/ns
Operating junction temp (T_J)	-40°C to 125°C

Thermal Resistance ⁽⁴⁾	θ_{JA}	θ_{JC}	
QFN-10 (4mmx4mm)	47	7	°C/W

NOTES:

- 1) Exceeding these ratings may damage the device.
- 2) The maximum allowable power dissipation is a function of the maximum junction temperature T_J (MAX), the junction-to-ambient thermal resistance θ_{JA} , and the ambient temperature T_A . The maximum allowable continuous power dissipation at any ambient temperature is calculated by P_D (MAX) = $(T_J$ (MAX) - T_A) / θ_{JA} . Exceeding the maximum allowable power dissipation produces an excessive die temperature, causing the regulator to go into thermal shutdown. Internal thermal shutdown circuitry protects the device from permanent damage.
- 3) The device is not guaranteed to function outside of its operating conditions.
- 4) Measured on JESD51-7, 4-layer PCB.

ELECTRICAL CHARACTERISTICS

$V_{DD} = V_{BST} - V_{SW} = 12V$, $V_{SS} = V_{SW} = 0V$, no load at DRVH and DRV L, $T_A = +25^{\circ}C$, unless otherwise noted.

Parameter	Symbol	Condition	Min	Typ	Max	Units
Supply Currents						
VDD quiescent current	I_{DDQ}	INL = INH = 0		100	150	μA
VDD operating current	I_{DDO}	fsw = 500kHz		9		mA
Floating driver quiescent current	I_{BSTQ}	INL = INH = 0		60	90	μA
Floating driver operating current	I_{BSTO}	fsw = 500kHz		7.5		mA
Leakage current	I_{LK}	BST = SW = 100V		0.05	1	μA
Inputs						
INL/INH high				2	2.4	V
INL/INH low			1	1.4		V
INL/INH internal pull-down resistance	R_{IN}			185		k Ω
Under-Voltage Protection						
VDD rising threshold	V_{DDR}		6.4	6.8	7.2	V
VDD hysteresis	V_{DDH}			0.5		V
BST-SW rising threshold	V_{BSTR}		6.1	6.5	6.9	V
BST-SW hysteresis	V_{BSTH}			0.5		V
Bootstrap Diode						
Bootstrap diode VF at 100 μA	V_{F1}			0.5		V
Bootstrap diode VF at 100mA	V_{F2}			0.95		V
Bootstrap diode dynamic R	R_D	At 100mA		2.5		Ω
Low-Side Gate Driver						
Low-level output voltage	V_{OLL}	$I_o = 100mA$		0.1		V
High-level output voltage to rail	V_{OHL}	$I_o = -100mA$		0.36		V
Source current ⁽⁵⁾	I_{OHL}	$V_{DRVL} = 0V, V_{DD} = 12V$		3		A
		$V_{DRVL} = 0V, V_{DD} = 16V$		4.7		A
Sink current ⁽⁵⁾	I_{OLL}	$V_{DRVL} = V_{DD} = 12V$		4.5		A
		$V_{DRVL} = V_{DD} = 16V$		6		A
Floating Gate Driver						
Low-level output voltage	V_{OLH}	$I_o = 100mA$		0.1		V
High-level output voltage to rail	V_{OHH}	$I_o = -100mA$		0.32		V
Source current ⁽⁵⁾	I_{OHH}	$V_{DRVH} = 0V, V_{DD} = 12V$		2.6		A
		$V_{DRVH} = 0V, V_{DD} = 16V$		4		A
Sink current ⁽⁵⁾	I_{OLH}	$V_{DRVH} = V_{DD} = 12V$		4.5		A
		$V_{DRVH} = V_{DD} = 16V$		5.9		A

ELECTRICAL CHARACTERISTICS (continued)

$V_{DD} = V_{BST} - V_{SW} = 12V$, $V_{SS} = V_{SW} = 0V$, no load at DRVH and DRVL, $T_A = +25^{\circ}C$, unless otherwise noted.

Parameter	Symbol	Condition	Min	Typ	Max	Units
Switching Specification – Low-Side Gate Driver						
Turn-off propagation delay INL falling to DRVL falling	T_{DLFF}			20		ns
Turn-on propagation delay INL rising to DRVL rising	T_{DLRR}			20		
DRVL rise time		$C_L = 2.2nF$		15		ns
DRVL fall time		$C_L = 2.2nF$		15		ns
Switching Specification – Floating Gate Driver						
Turn-off propagation delay INH falling to DRVH falling	T_{DHFF}			20		ns
Turn-on propagation delay INH rising to DRVH rising	T_{DHRR}			20		ns
DRVH rise time		$C_L = 2.2nF$		15		ns
DRVH fall time		$C_L = 2.2nF$		15		ns
Switching Specification – Matching						
Floating driver turn-off to low-side driver turn-on ⁽⁵⁾	T_{MON}			1	5	ns
Low-side driver turn-off to floating driver turn-on ⁽⁵⁾	T_{MOFF}			1	5	ns
Minimum input pulse width that changes the output ⁽⁵⁾	T_{PW}				50	ns
Bootstrap diode turn-on or turn- off time ⁽⁵⁾	T_{BS}			10		ns
Thermal shutdown				150		$^{\circ}C$
Thermal shutdown hysteresis				25		$^{\circ}C$

NOTE:

5) Guaranteed by design.

TYPICAL PERFORMANCE CHARACTERISTICS

$V_{DD} = 12V$, $V_{SS} = V_{SW} = 0V$, $T_A = +25^\circ C$, unless otherwise noted.

I_{DDO} Operation Current vs. Frequency

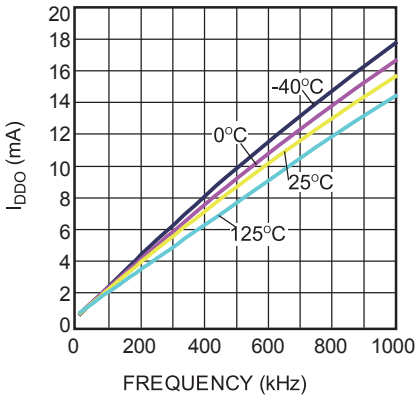

I_{BSTO} Operation Current vs. Frequency

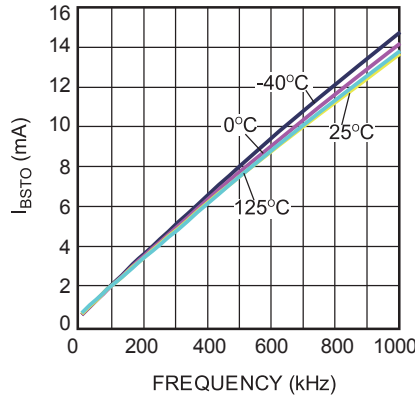

High-Level Output Voltage vs. Temperature

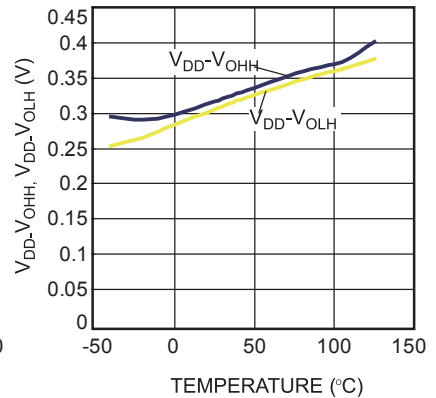

Low-Level Output Voltage vs. Temperature

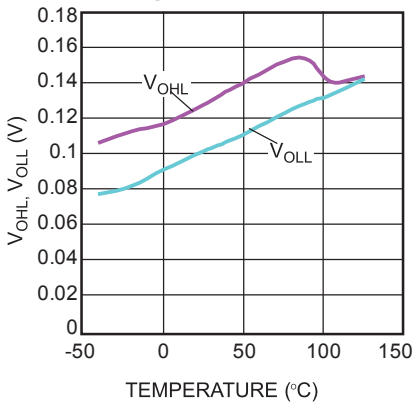

Under-Voltage Lockout Threshold vs. Temperature

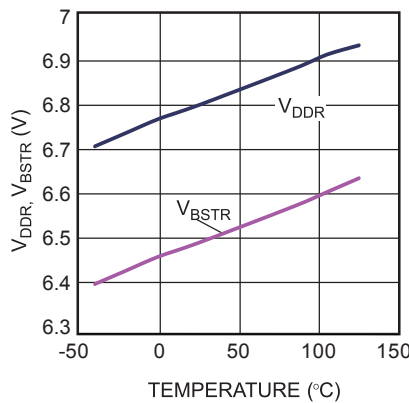

Under-Voltage Lockout Hysteresis vs. Temperature

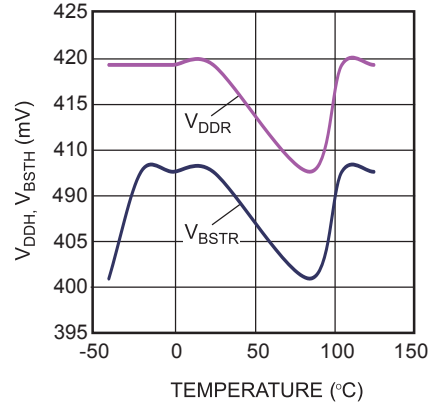

Bootstrap Diode I-V Characteristic

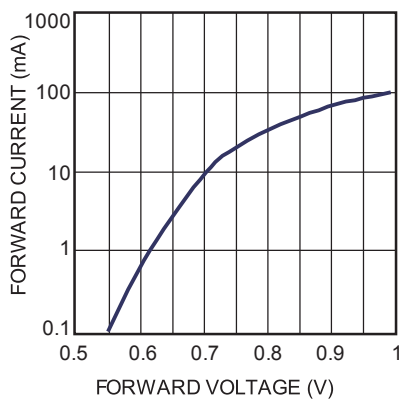

Quiescent Current vs. Voltage

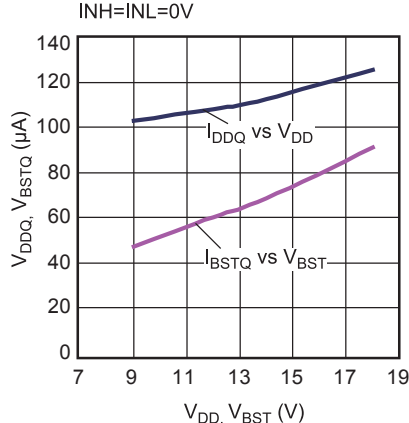

Propagation Delay vs. Temperature

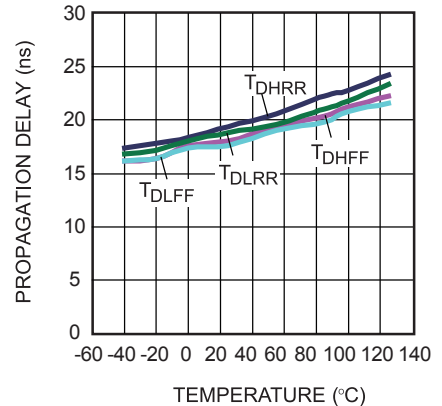

TYPICAL PERFORMANCE CHARACTERISTICS (continued)
 $V_{DD} = 12V$, $V_{SS} = V_{SW} = 0V$, $T_A = +25^\circ C$, unless otherwise noted.

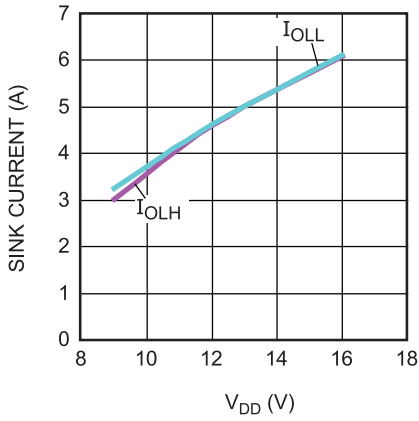
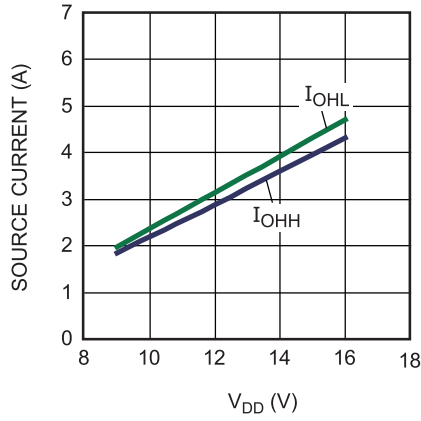
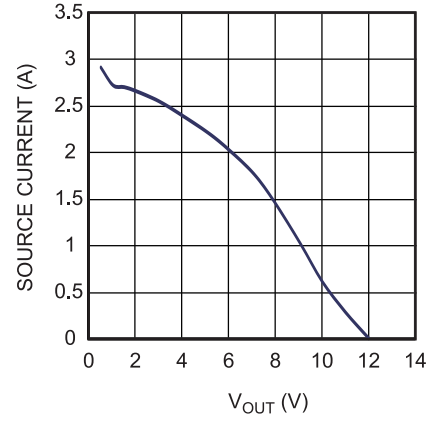
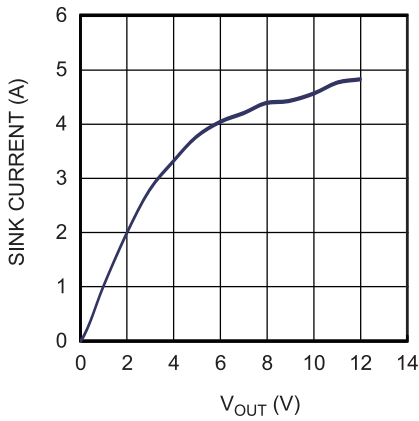
Sink Current vs. V_{DD} Voltage

Source Current vs. V_{DD} Voltage

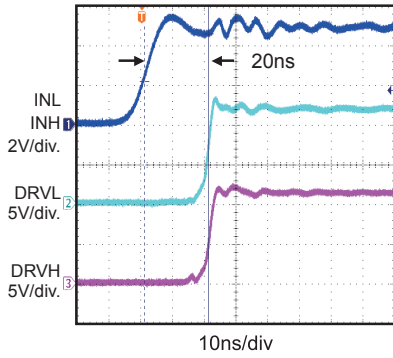
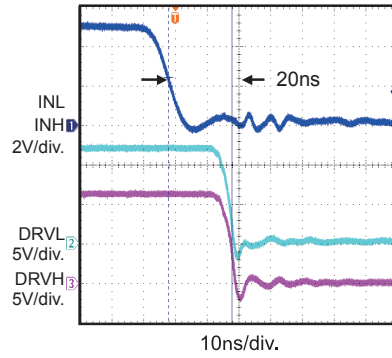
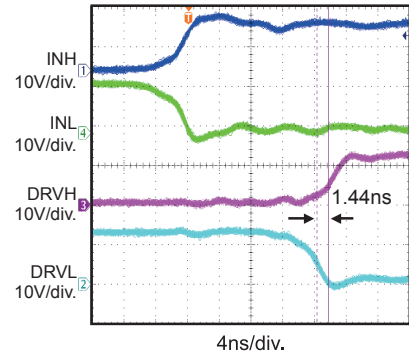
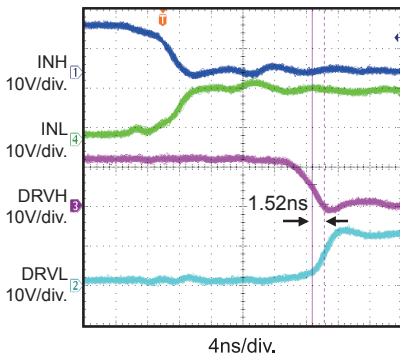
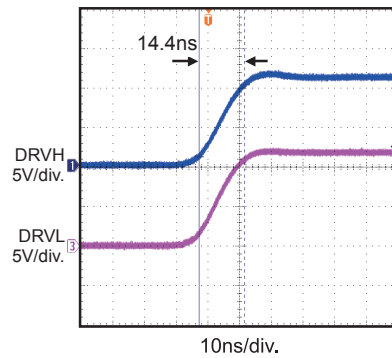
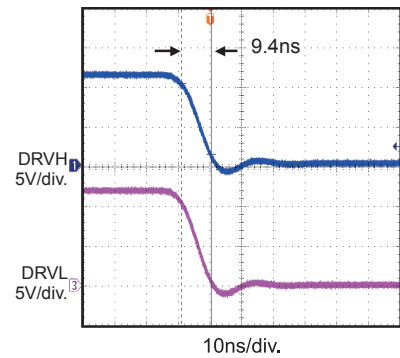
Source Current vs. Output Voltage
 $V_{DD} = 12V$

Sink Current vs. Output Voltage
 $V_{DD} = 12V$

TYPICAL PERFORMANCE CHARACTERISTICS (continued)
 $V_{DD} = 12V, V_{SS} = V_{SW} = 0V, T_A = +25^\circ C$, unless otherwise noted.

Turn-On Propagation Delay

Turn-Off Propagation Delay

Gate Drive Matching T_{MOFF}

Gate Drive Matching T_{MON}

**Drive Rise Time
2.2nF Load**

**Drive Fall Time
2.2nF Load**

PIN FUNCTIONS

Pin #	Name	Description
1	VDD	Supply input. VDD supplies power to the internal circuitry. Place a decoupling capacitor on ground close to VDD to ensure a stable and clean supply.
2	BST	Bootstrap. Positive power supply for the internal floating high-side MOSFET driver. Connect a bypass capacitor between BST and SW.
3	DRVH	Floating driver output.
4	SW	Switching node.
5, 6	NC	No connection.
7	INH	Control signal input for the floating driver.
8	INL	Control signal input for the low-side driver.
9	VSS, exposed pad	Chip ground. Connect the exposed pad to VSS for proper thermal operation.
10	DRVL	Low-side driver output.

TIMING DIAGRAM

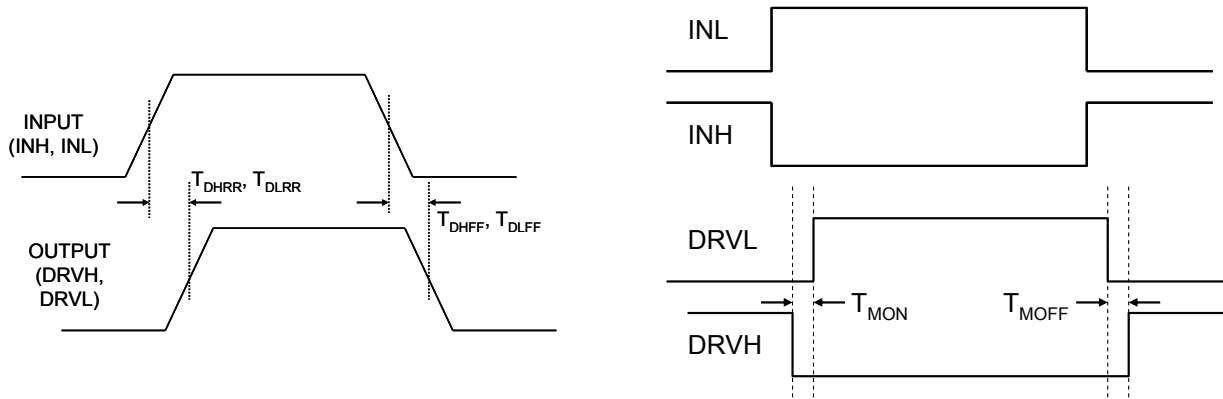

Figure 1: Timing Diagram

FUNCTIONAL BLOCK DIAGRAM

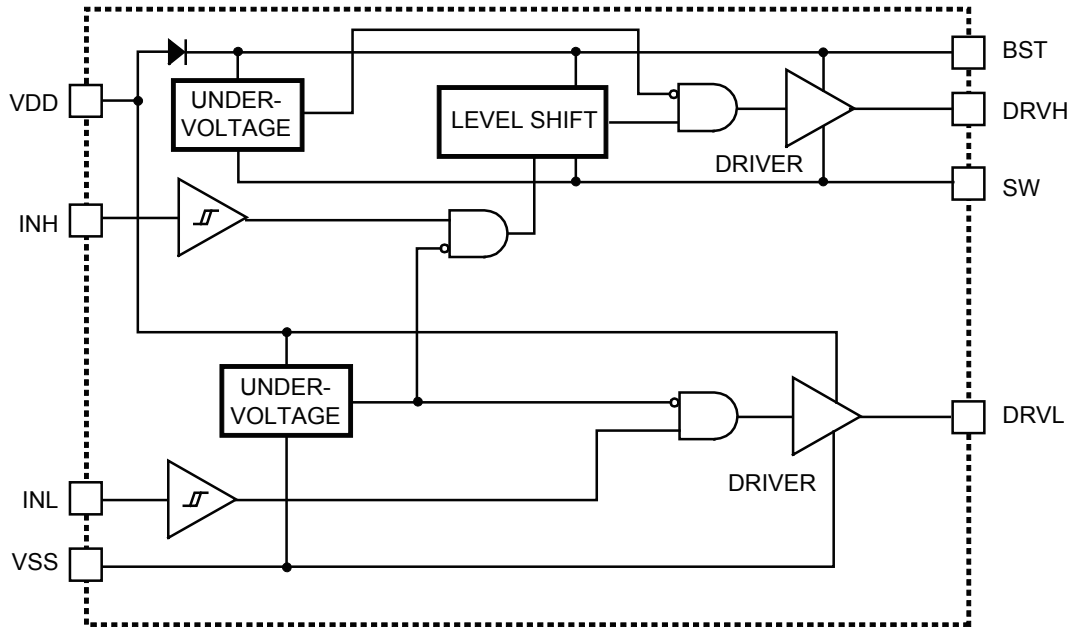

Figure 2: Functional Block Diagram

APPLICATION INFORMATION

The INH and INL input signals can be controlled independently. If both INH and INL control the high-side and low-side MOSFETs of the same bridge, set a sufficient dead time between INH

and INL low, and vice versa, to avoid shoot-through (see Figure 3). Dead time is defined as the time interval between INH low and INL low.

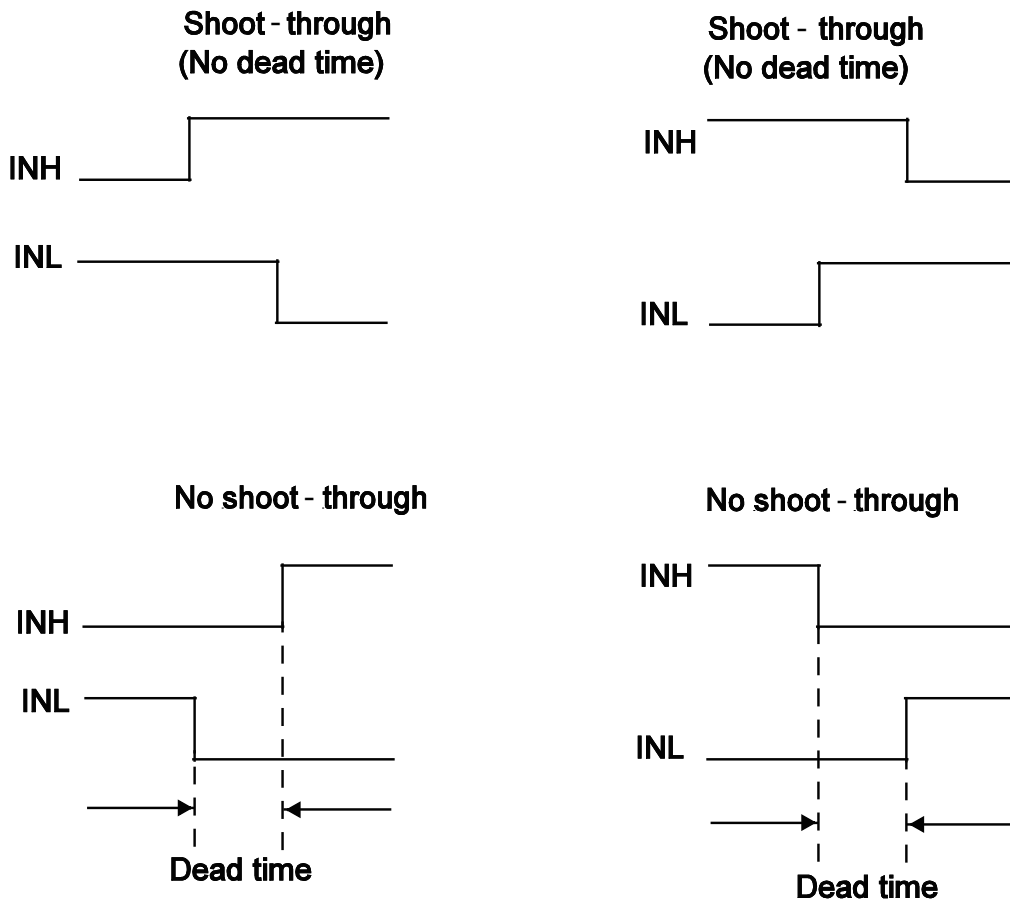

Figure 3: Shoot-Through Timing Diagram

REFERENCE DESIGN CIRCUITS

Half-Bridge Converter

The MP1917A drives the MOSFETS with alternating signals with dead time in half-bridge converter topology. The input voltage can rise up

to 100V with the alternating signals INT and INL coming from the PWM controller (see Figure 4).

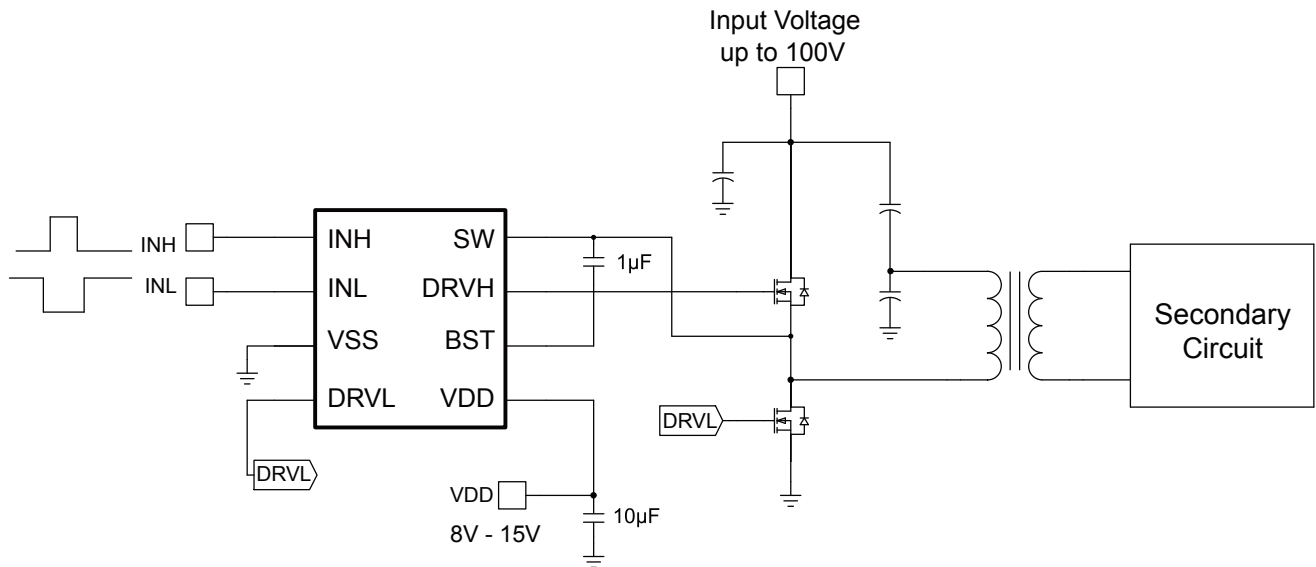

Figure 4: Half-Bridge Converter

Two-Switch Forward Converter

In two-switch forward converter topology, both MOSFETs are turned on and off simultaneously. The INH and INL input signals come from a PWM controller that senses the output voltage and output current during current-mode control.

The Schottky diodes clamp the reverse swing of the power transformer, and must be rated for the input voltage. The input voltage can rise up to 100V (see Figure 5).

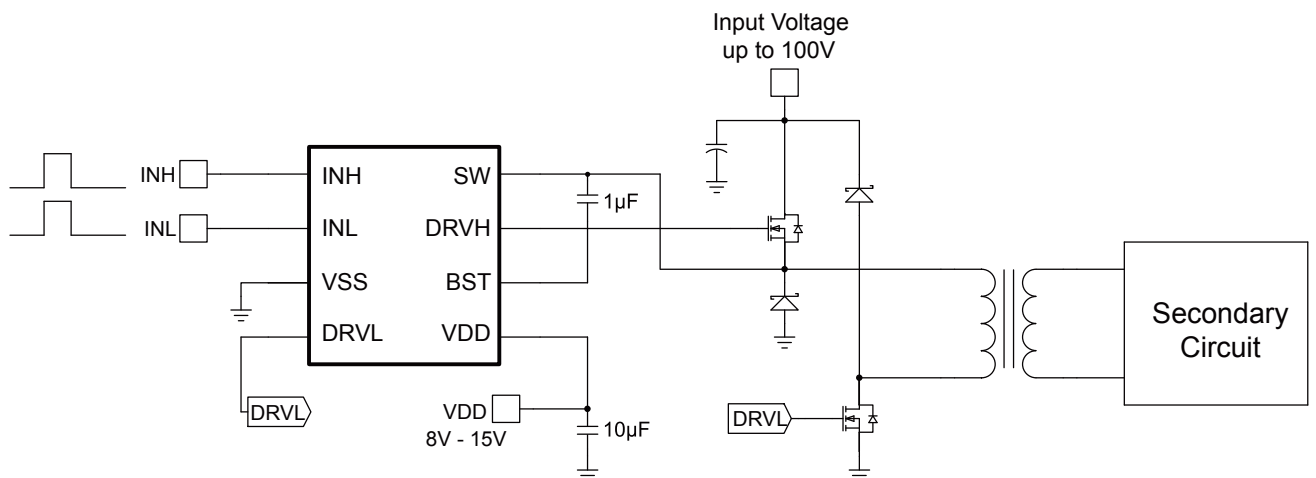

Figure 5: Two-Switch Forward Converter

Active Clamp Forward Converter

In active clamp forward converter topology, the MP1917A drives the MOSFETs with alternating signals. The high-side MOSFET, in conjunction with C_{reset} , is used to reset the power transformer with minimal power loss.

This topology is optimal for running at duty cycles exceeding 50%. The device may not be able to run at 100V under this topology (see Figure 6).

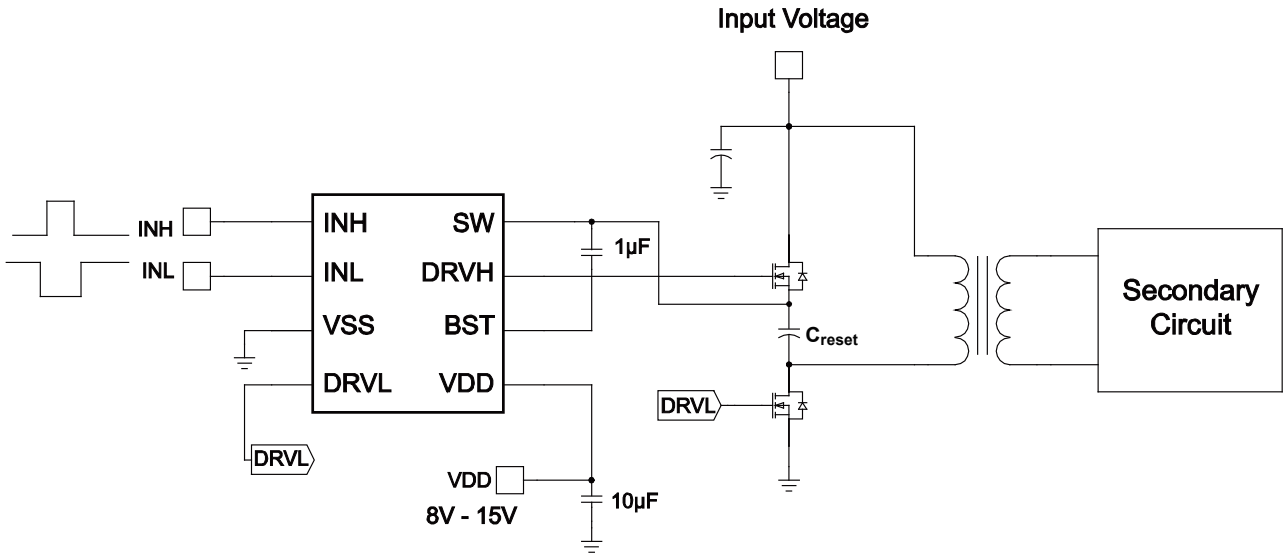
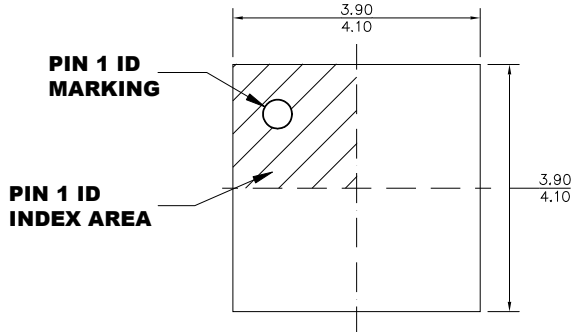

Figure 6: Active Clamp Forward Converter

PACKAGE INFORMATION

QFN-10 (4mmx4mm)



TOP VIEW

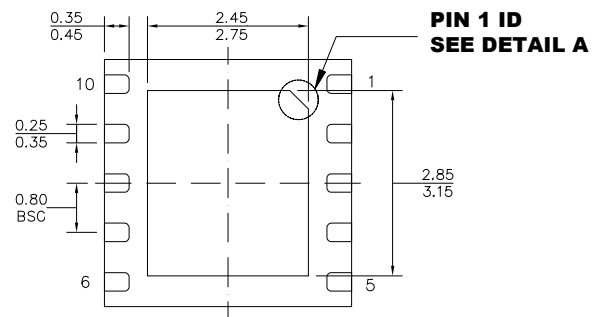

BOTTOM VIEW

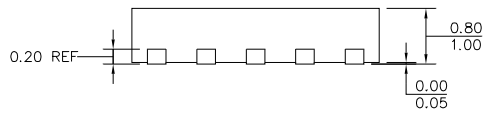

SIDE VIEW

**PIN 1 ID OPTION A
0.30x45° TYP.**



**PIN 1 ID OPTION B
R0.25 TYP.**



DETAIL A

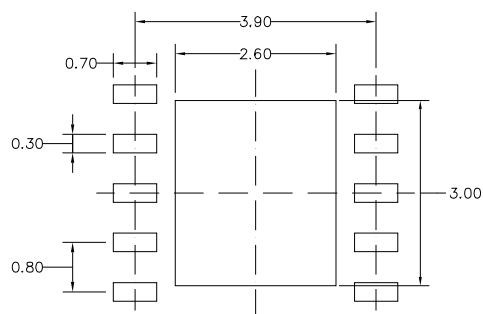

RECOMMENDED LAND PATTERN

NOTE:

- 1) ALL DIMENSIONS ARE IN MILLIMETERS.
- 2) EXPOSED PADDLE SIZE DOES NOT INCLUDE MOLD FLASH.
- 3) LEAD COPLANARITY SHALL BE 0.10 MILLIMETERS MAX.
- 4) JEDEC REFERENCE IS MO-220.
- 5) DRAWING IS NOT TO SCALE.

NOTICE: The information in this document is subject to change without notice. Please contact MPS for current specifications. Users should warrant and guarantee that third-party Intellectual Property rights are not infringed upon when integrating MPS products into any application. MPS will not assume any legal responsibility for any said applications.