

# L8050HRLT1G

## S-L8050HRLT1G

General Purpose Transistors NPN Silicon

### 1. FEATURES

- We declare that the material of product compliance with RoHS requirements and Halogen Free.
- S- prefix for automotive and other applications requiring unique site and control change requirements; AEC-Q101 qualified and PPAP capable.
- High current capacity in compact package.
- Epitaxial planar type.

### 2. DEVICE MARKING AND ORDERING INFORMATION

Device	Marking	Shipping
L8050HRLT1G	1HE	3000/Tape&Reel
L8050HRLT3G	1HE	10000/Tape&Reel

### 3. MAXIMUM RATINGS(Ta = 25°C)

Parameter	Symbol	Limits	Unit
Collector-Emitter Voltage	VCEO	25	V
Collector-Base voltage	VCBO	40	V
Emitter-Base Voltage	VEBO	5	V
Collector current	IC	1500	mA

### 4. THERMAL CHARACTERISTICS

Parameter	Symbol	Limits	Unit
Total Device Dissipation, FR-5 Board (Note 1) @ TA = 25°C Derate above 25°C	PD	225 1.8	mW mW/°C
Thermal Resistance, Junction-to-Ambient	RθJA	556	°C/W
Total Device Dissipation, Alumina Substrate, (Note 2) @ TA = 25°C Derate above 25°C	PD	300 2.4	mW mW/°C
Thermal Resistance, Junction-to-Ambient	RθJA	417	°C/W
Junction and Storage temperature	TJ,Tstg	-55~+150	°C

1. FR-5 = 1.0×0.75×0.062 in.

2. Alumina = 0.4 x 0.3 x 0.024 in. 99.5% alumina.

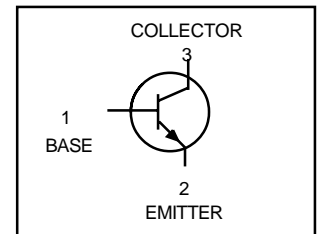
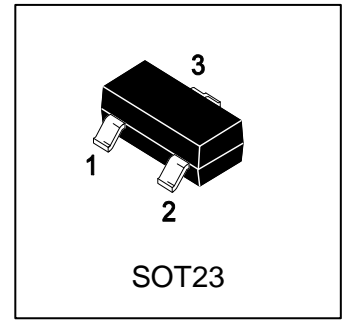

### 5. ELECTRICAL CHARACTERISTICS (Ta= 25°C)

#### OFF CHARACTERISTICS

Characteristic	Symbol	Min.	Typ.	Max	Unit
Collector-Emitter Breakdown Voltage (IC =1.0mA)	V(BR)CEO	25	-	-	V
Emitter-Base Breakdown Voltage (IE = 100μA)	V(BR)EBO	5	-	-	V
Collector-Base Breakdown voltage (IC = 100μA)	V(BR)CBO	40	-	-	V
Collector Cutoff Current (VCB = 35 V)	ICBO	-	-	150	nA
Emitter Cutoff Current (VEB = 4V)	IEBO	-	-	150	nA
Collector-Emitter cutoff Current (VCE=25V,IB=0)	ICEO	-	-	100	μA

#### ON CHARACTERISTICS

DC Current Gain (IC =100mA, VCE =1V)	HFE	200	-	400	
Collector-Emitter Saturation Voltage (IC =800mA, IB =80mA) (IC =500mA, IB =20mA)	VCE(S)	-	-	0.5 0.4	V

**6.ELECTRICAL CHARACTERISTICS CURVES**

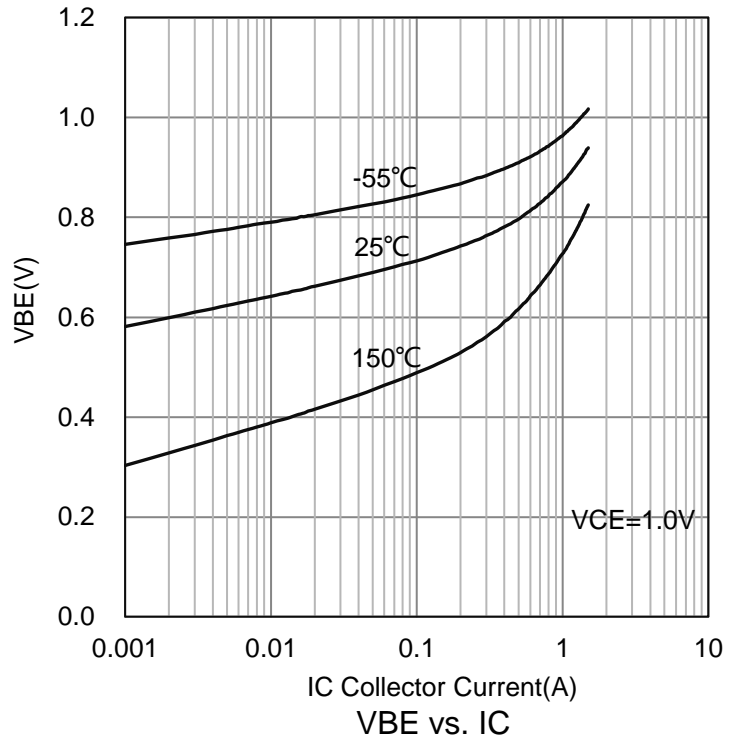
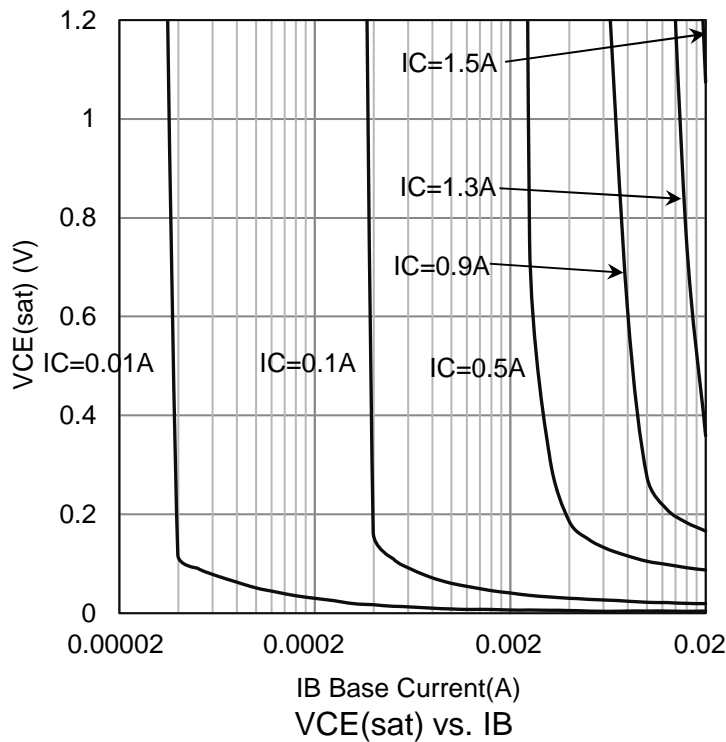
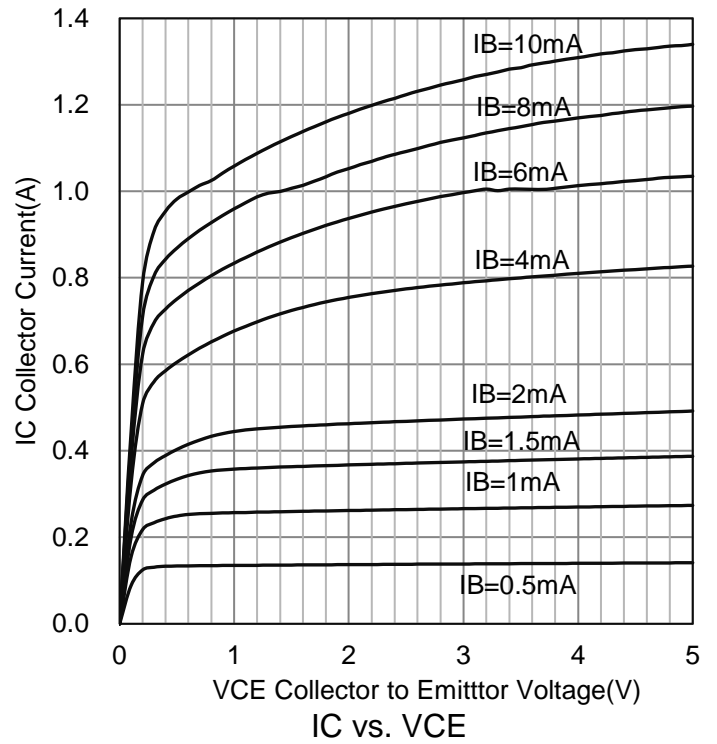
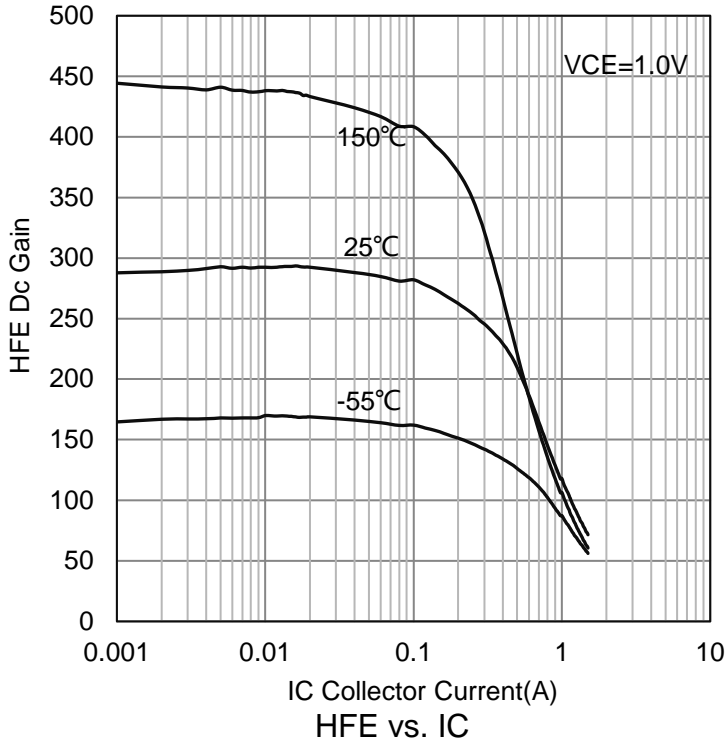

**6.ELECTRICAL CHARACTERISTICS CURVES(Con.)**

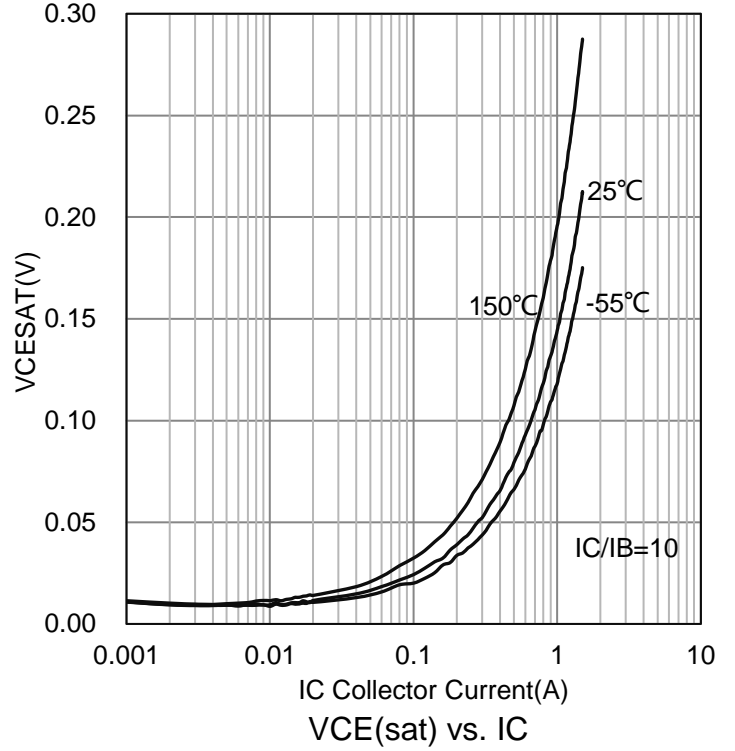
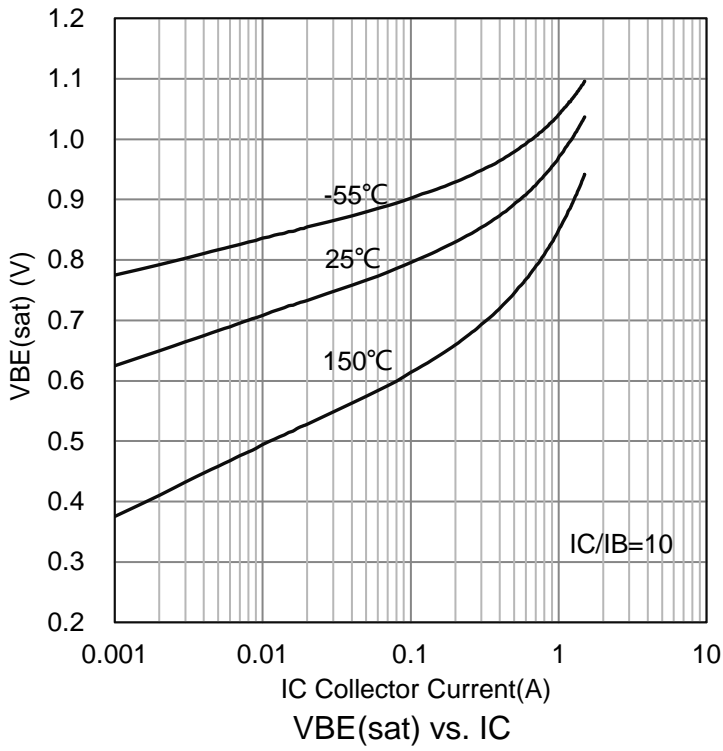

### 7. OUTLINE AND DIMENSIONS

Notes:

1. DIMENSIONING AND TOLERANCING PER ANSI Y14.5M, 1982.
2. CONTROLLING DIMENSION: MILLIMETERS.
3. MAXIMUM LEAD THICKNESS INCLUDES LEAD FINISH. MINIMUM LEAD THICKNESS IS THE MINIMUM THICKNESS OF BASE MATERIAL.
4. DIMENSIONS D AND E DO NOT INCLUDE MOLD FLASH, PROTRUSIONS OR GATE BURRS.

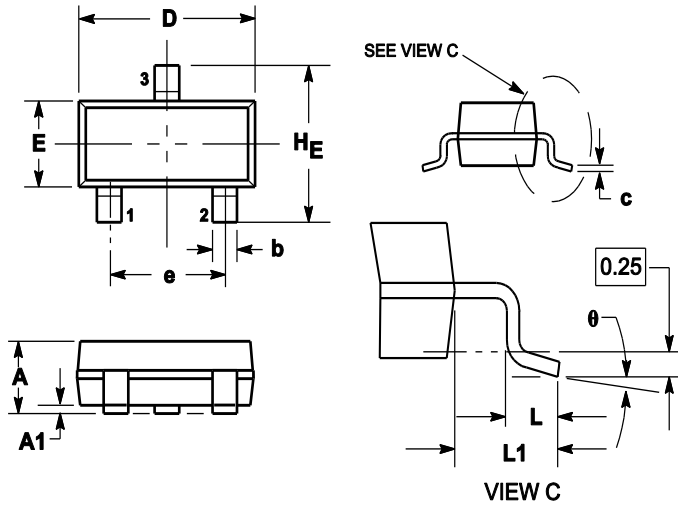

DIM	MILLIMETERS			INCHES		
	MIN	NOM	MAX	MIN	NOM	MAX
A	0.89	1	1.11	0.035	0.04	0.044
A1	0.01	0.06	0.1	0.001	0.002	0.004
b	0.37	0.44	0.5	0.015	0.018	0.02
c	0.09	0.13	0.18	0.003	0.005	0.007
D	2.80	2.9	3.04	0.11	0.114	0.12
E	1.20	1.3	1.4	0.047	0.051	0.055
e	1.78	1.9	2.04	0.07	0.075	0.081
L	0.10	0.2	0.3	0.004	0.008	0.012
L1	0.35	0.54	0.69	0.014	0.021	0.029
HE	2.10	2.4	2.64	0.083	0.094	0.104
θ	0°	---	10°	0°	---	10°

### 8. SOLDERING FOOTPRINT

