

# LMP22D5N3T5G

## 20V P-Channel Enhancement MOSFET

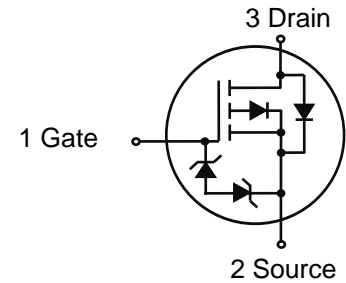
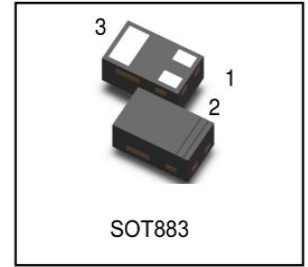

### 1. FEATURES

- VDS = -20V
- Gate-Source ESD Protected.
- High-Side Switching.
- Low On-Resistance.
- Low Threshold.
- Fast Switching Speed.
- We declare that the material of product compliance with RoHS requirements and Halogen Free.

### 2. APPLICATIONS

- Drivers: Relays, Solenoids, Lamps, Hammers, Displays, Memories.
- Battery Operated Systems.
- Power Supply Converter Circuits.
- Load/Power Switching Cell Phones, Pagers.

### 3. DEVICE MARKING AND ORDERING INFORMATION

Device	Marking	Shipping
LMP22D5N3T5G	PG	10000/Tape&Reel

### 4. MAXIMUM RATINGS(Ta = 25°C)

Parameter		Symbol	10 secs	Steady State	Unit
Drain-to-Source Voltage		VDSS	-20		V
Gate-to-Source Voltage		VGS	±8		V
Continuous Drain Current	TA = 25°C	ID	-850	-700	mA
	TA = 70°C		-670	-600	
Pulsed Drain Current (Note2)		IDM	-2000		
Maximum Power Dissipation (Note1)		PD	350		mW
Operating Junction and Storage Temperature Range		TJ/Tstg	-55~+150		°C

### 5. THERMAL CHARACTERISTICS

Parameter	Symbol	Limits	Unit
Junction-to-Ambient - Steady State (Note 1)	ROJA	357	°C/W

1. FR-4 = 30.0mm×25.0mm×1.6mm
2. Pulse width limited by maximum junction temperature.

**6. ELECTRICAL CHARACTERISTICS (Ta= 25°C)**

Characteristic	Symbol	Min.	Typ.	Max.	Unit	
<b>Static</b>						
Drain-Source Breakdown Voltage (VGS = 0V, ID =-250uA)	V(BR)DSS	-20	-	-	V	
Gate Threshold Voltage (VDS =VGS , ID =-250μA)	VGS(th)	-0.4	-0.68	-1	V	
Gate Body Leakage Current (VDS =0V, VGS =±8V)	IGSS	-	-	±10	μA	
Zero Gate Voltage Drain Current (VDS =-20V, VGS =0V)	IDSS	-	-	-1	μA	
Drain-Source On-State Resistance (VGS=-4.5V, ID=-0.2A) (VGS=-2.5V, ID=-0.2A) (VGS=-1.8V, ID=-0.2A)	RDS(ON)	-	-	400 500 600	mΩ	
Diode Forward Voltage (IS = -1.0A, VGS = 0V)	VSD	-	-	-1.5	V	
<b>Dynamic</b>						
Total Gate Charge	(VDS =-16V, VGS =-4.5V, ID =-200mA)	Qg	-	1.3	-	nC
Gate-Source Charge		Qgs	-	0.15	-	
Gate-Drain Charge		Qgd	-	0.53	-	
Turn-On Delay Time	(VDD =-10V, RL =50Ω, VGEN =- 5V, RG =10Ω, ID =-200mA)	td(on)	-	26	-	ns
Rise Time		tr	-	66	-	
Turn-Off Delay Time		td(off)	-	82	-	
Fall Time		tf	-	280	-	
Input Capacitance	(VDS = -16 V, VGS = 0 V, f = 1 MHz)	Ciss	-	53	-	pF
Output Capacitance		Coss	-	9.8	-	
Reverse Transfer Capacitance		Crss	-	6.3	-	

3. Pulse test; pulse width ≤ 300μs, duty cycle ≤ 2%.

7 ELECTRICAL CHARACTERISTICS CURVES

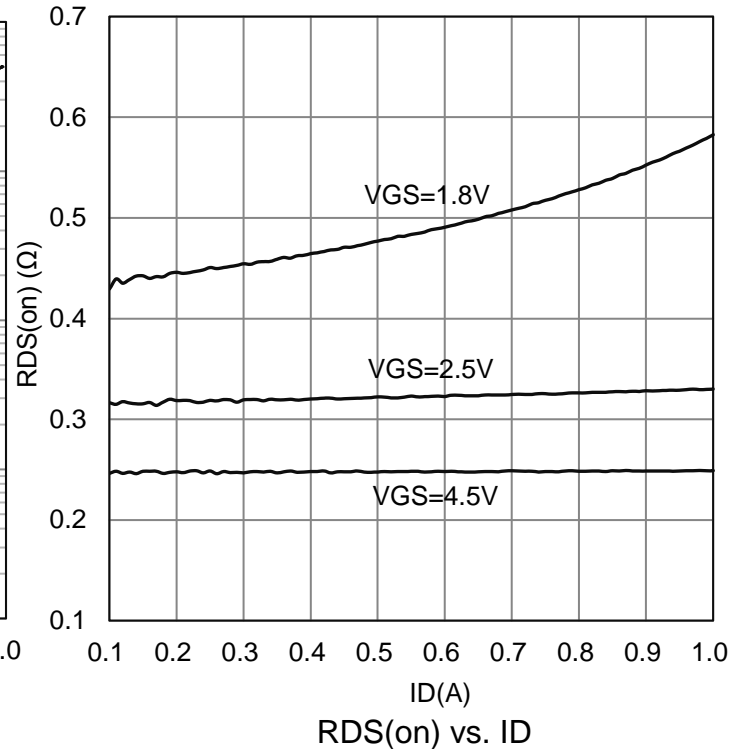
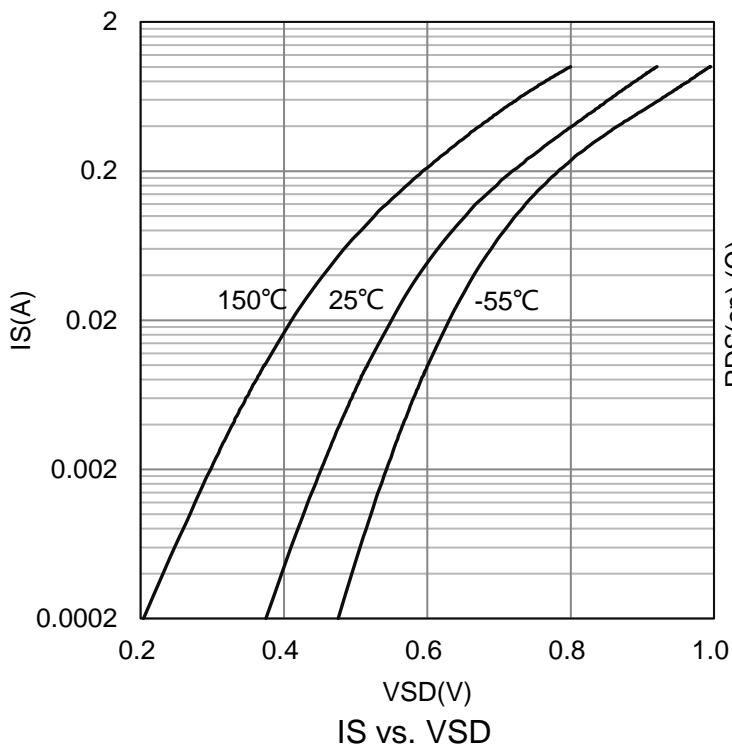
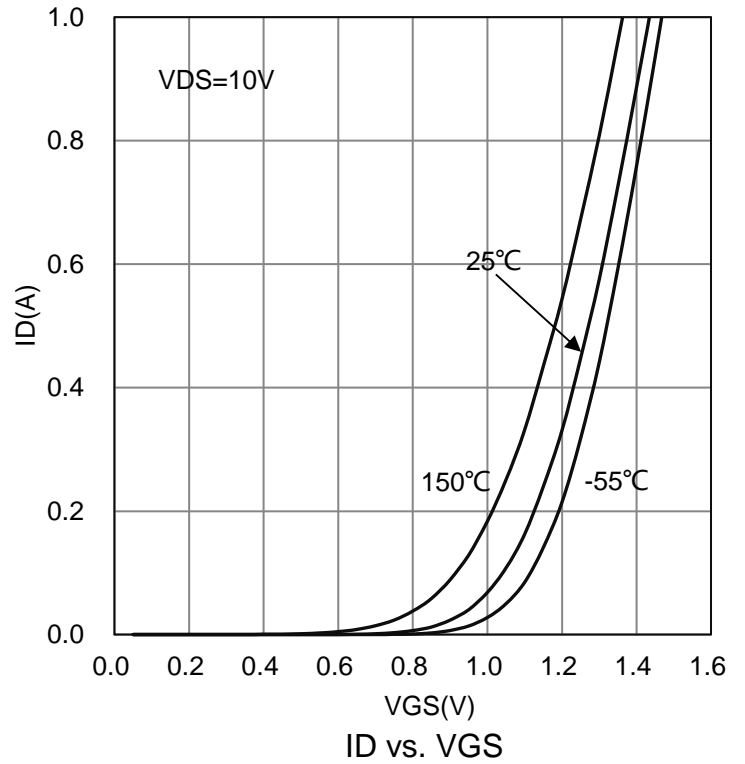
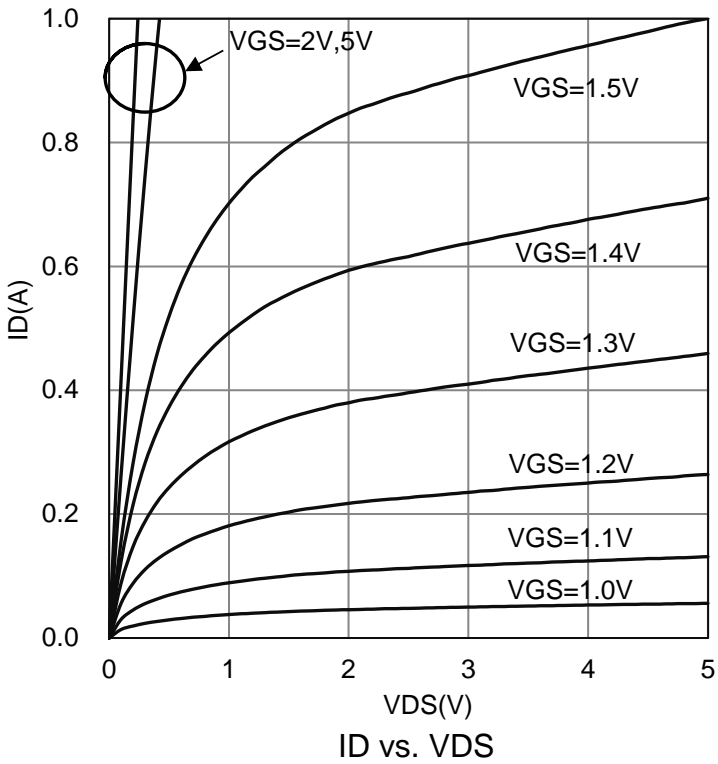

**7 .ELECTRICAL CHARACTERISTICS CURVES(Con.)**

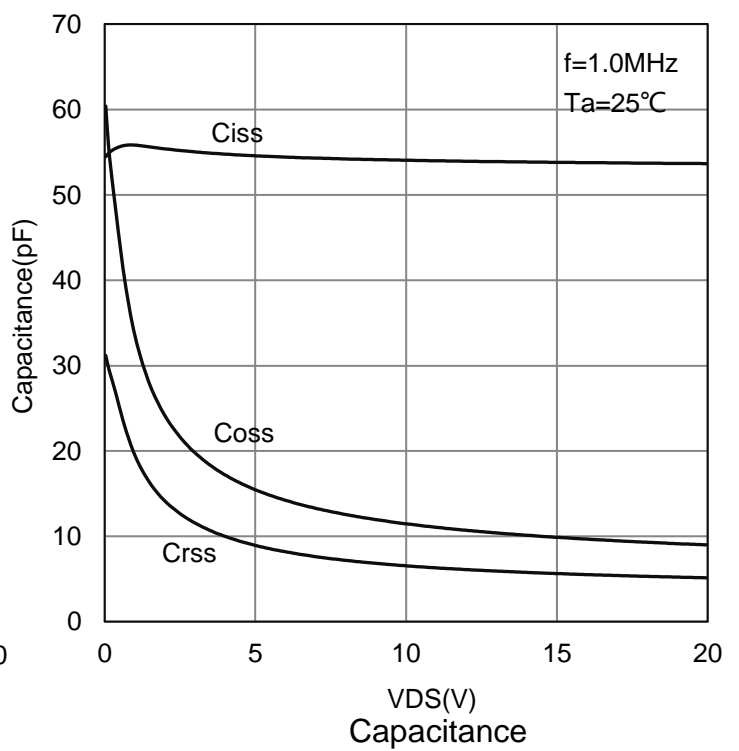
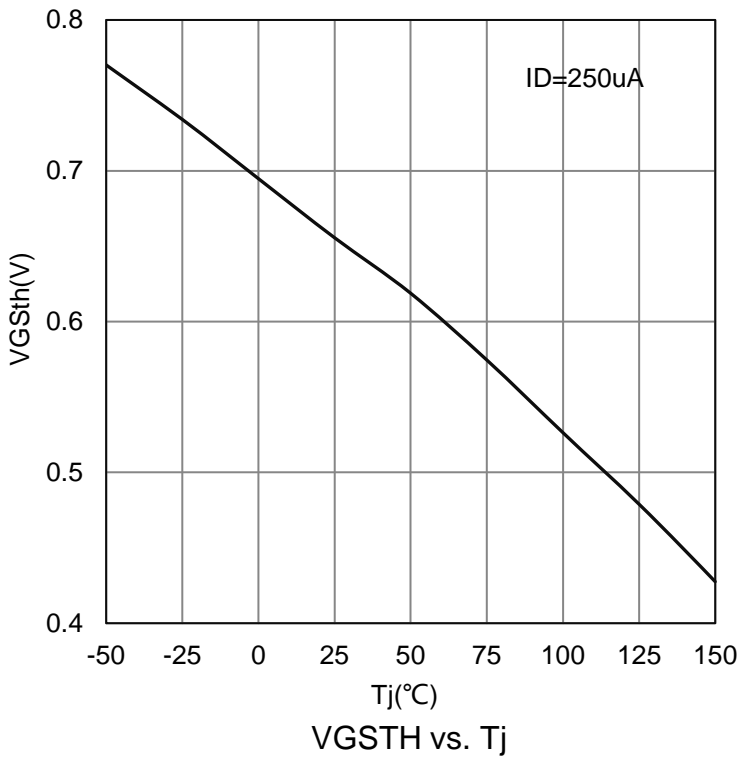
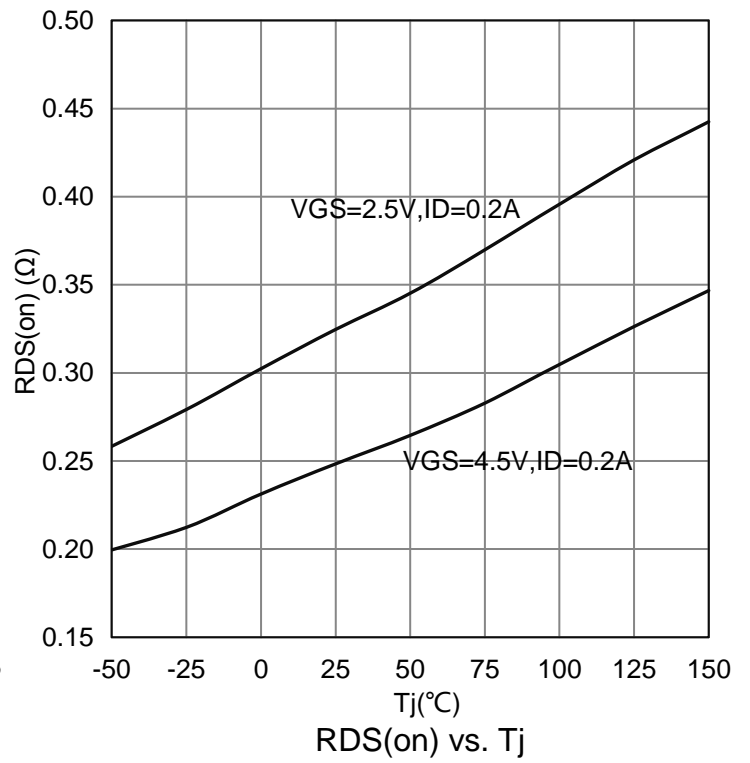
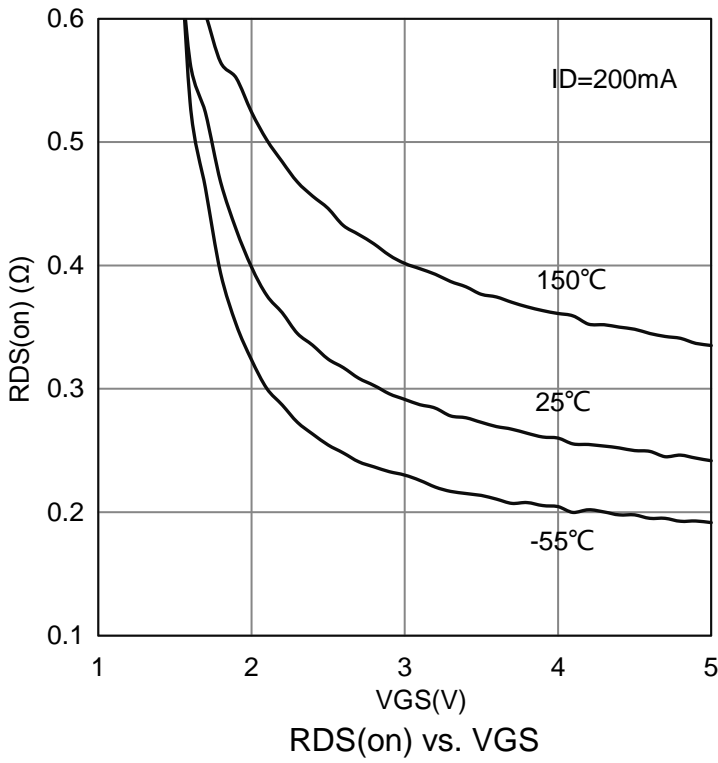

**7. ELECTRICAL CHARACTERISTICS CURVES(Con.)**

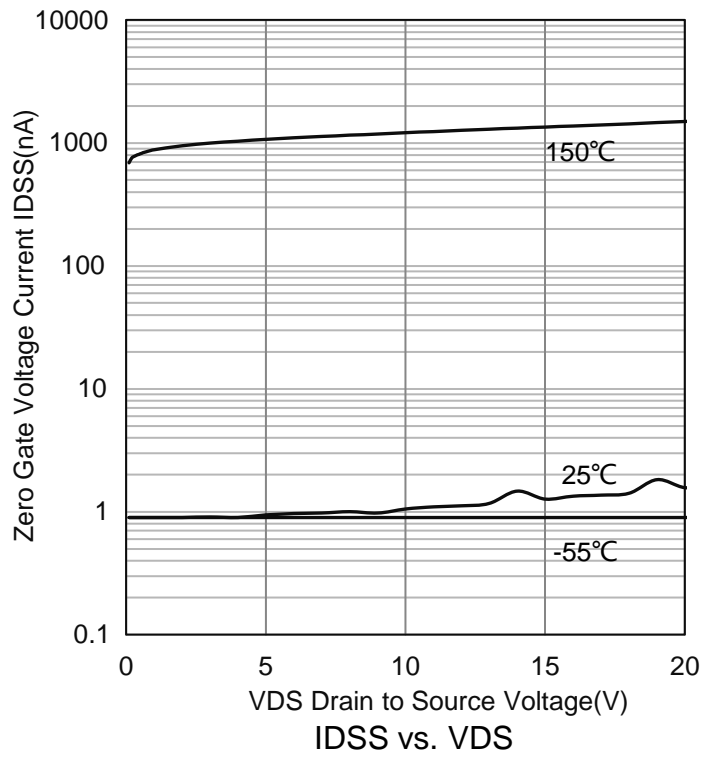
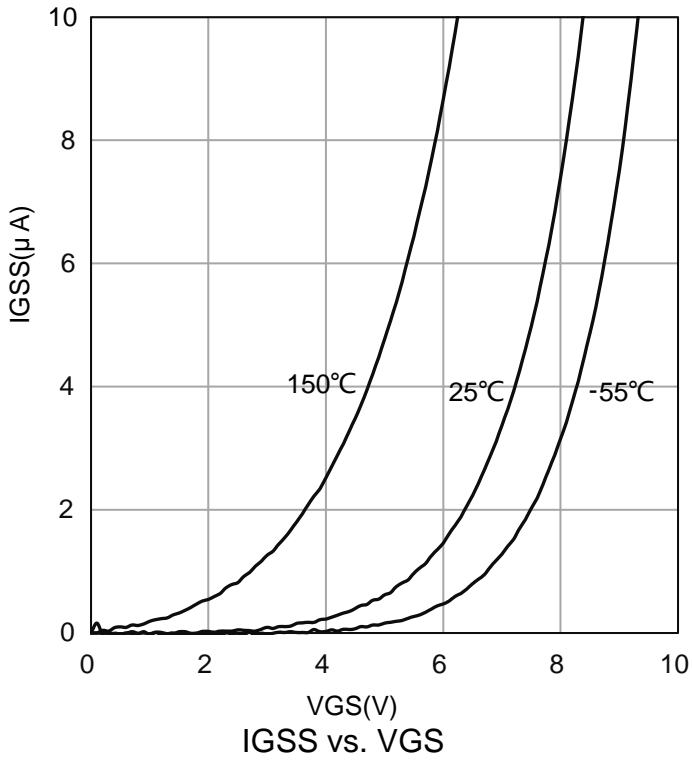

### 8. OUTLINE AND DIMENSIONS

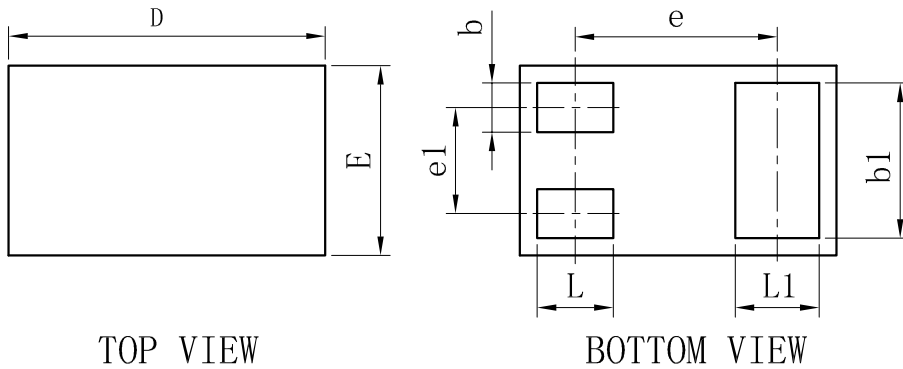

TOP VIEW

BOTTOM VIEW

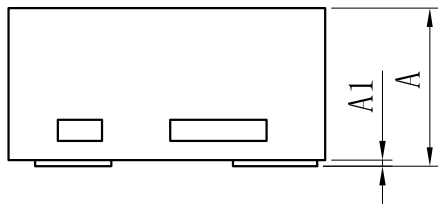

SIDE VIEW

SOT883			
Dim	Min	Typ	Max
D	0.95	1.00	1.05
E	0.55	0.60	0.65
e	-	0.64	-
e1	-	0.34	-
L	0.19	0.24	0.29
L1	0.22	0.27	0.32
b	0.10	0.15	0.20
b1	0.44	0.49	0.54
A	0.43	0.48	0.53
A1	0	-	0.05
All Dimensions in mm			

### 9. SOLDERING FOOTPRINT

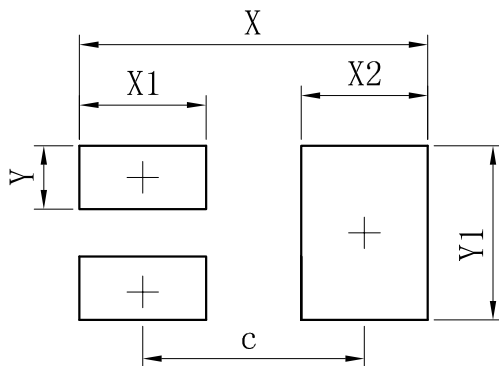

Dimensions	(mm)
c	0.70
X	1.10
X1	0.40
X2	0.40
Y	0.20
Y1	0.55

## **DISCLAIMER**

- Before you use our Products, you are requested to carefully read this document and fully understand its contents. LRC shall not be in any way responsible or liable for failure, malfunction or accident arising from the use of any LRC's Products against warning, caution or note contained in this document.
- All information contained in this document is current as of the issuing date and subject to change without any prior notice. Before purchasing or using LRC's Products, please confirm the latest information with a LRC sales representative.