

LN03N060TZHG

60V N-Channel Enhancement Mode MOSFET

1. FEATURES

- Low RDS(on) trench technology.
- Low thermal impedance.
- Fast switching speed.
- We declare that the material of product are Halogen Free and compliance with RoHS requirements.

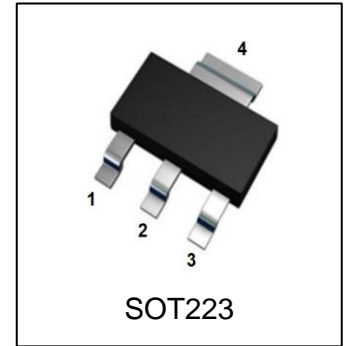

2. APPLICATION

- Power Routing
- DC/DC Conversion
- Motor Drives

3. ORDERING INFORMATION

Device	Marking	Shipping
LN03N060TZHG	SN	1000/Tape&Reel

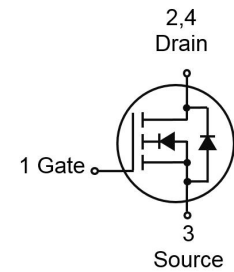

4. MAXIMUM RATINGS(Ta = 25°C unless otherwise stated)

Parameter	Symbol	Limits	Unit
Drain-to-Source Voltage	VDSS	60	V
Gate-to-Source Voltage	VGS	±20	V
Continuous Drain Current	ID	TA =25°C	5
		TA =70°C	3.8
Pulsed Drain Current (Note 1)	IDM	20	A
Avalanche Current(L=0.1mH)	IAS	13	A
Avalanche energy(L=0.1mH)	EAS	8.45	mJ
Power Dissipation TA =25°C	PD	2	W
Operating Junction and Storage Temperature Range	TJ , TSTG	-55 ~+150	°C

1.Pulse width limited by maximum junction temperature.

5. THERMAL CHARACTERISTICS

Parameter	Symbol	Limits	Unit
Thermal Resistance,Junction-to-Ambient (Note 2)	RθJA	65	°C/W
Thermal Resistance,Junction-to-Case (Note 2)	RθJC	15	°C/W

2. 1-in² 2oz Cu PCB board

6. ELECTRICAL CHARACTERISTICS

Characteristic	Symbol	Min.	Typ.	Max.	Unit
Static					
Drain to Source Breakdown Voltage (VGS = 0V, ID = 250μA)	V(BR)DSS	60	-	-	V
Gate-Source Threshold Voltage (VDS = VGS, ID = 250 uA)	VGS(th)	1	2	3.2	V
Gate-Body Leakage (VDS = 0 V, VGS = ±20 V)	IGSS	-	-	±100	nA
Zero Gate Voltage Drain Current (VDS = 48 V, VGS = 0 V)	IDSS	-	-	1	μA
Drain-Source On-Resistance(Note 3) (VGS = 10 V, ID = 3 A) (VGS = 5 V, ID = 2 A)	RDS(on)	- -	50 58	60 75	mΩ
Dynamic					
Total Gate Charge	(VDS = 30 V, VGS = 10 V, ID = 3A)	Qg	-	15	nC
Gate-Source Charge		Qgs	-	2.2	
Gate-Drain Charge		Qgd	-	4	
Turn-On Delay Time	(VDS = 30V, ID=1A, VGS = 10V RG = 6 Ω)	td(on)	-	10	ns
Rise Time		tr	-	12	
Turn-Off Delay Time		td(off)	-	20	
Fall Time		tf	-	15	
Input Capacitance	(VDS = 30 V, VGS = 0 V, f = 1 MHz)	Ciss	-	605	pF
Output Capacitance		Coss	-	40	
Reverse Transfer Capacitance		Crss	-	34	
Diode Forward Voltage(Note 3) (VGS=0V, IS=2.1A)	VSD	-	-	1.2	V
Gate Resistance (VDS=0V, VGS=0V, f=1.0MHz)	Rg	-	1.5	-	Ω

3. Pulse test: PW ≤ 300us duty cycle ≤ 2%.

7. ELECTRICAL CHARACTERISTICS CURVES

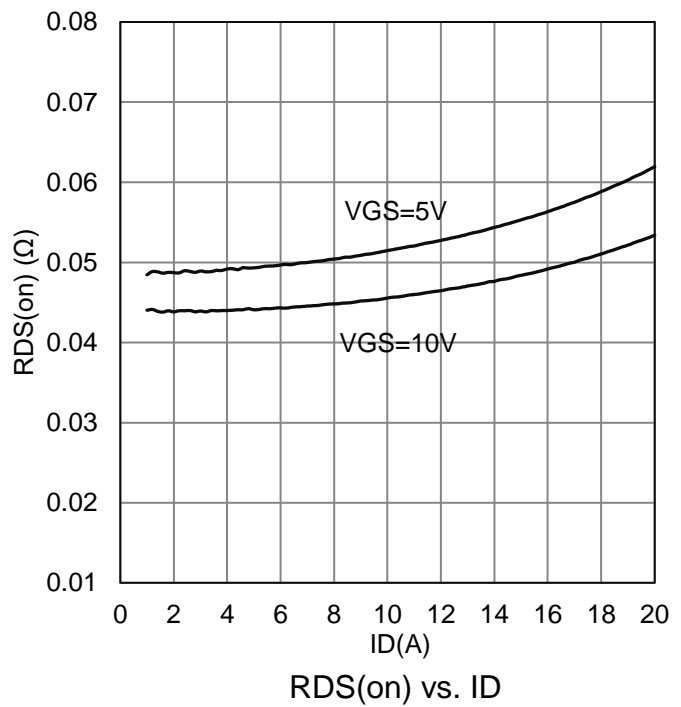
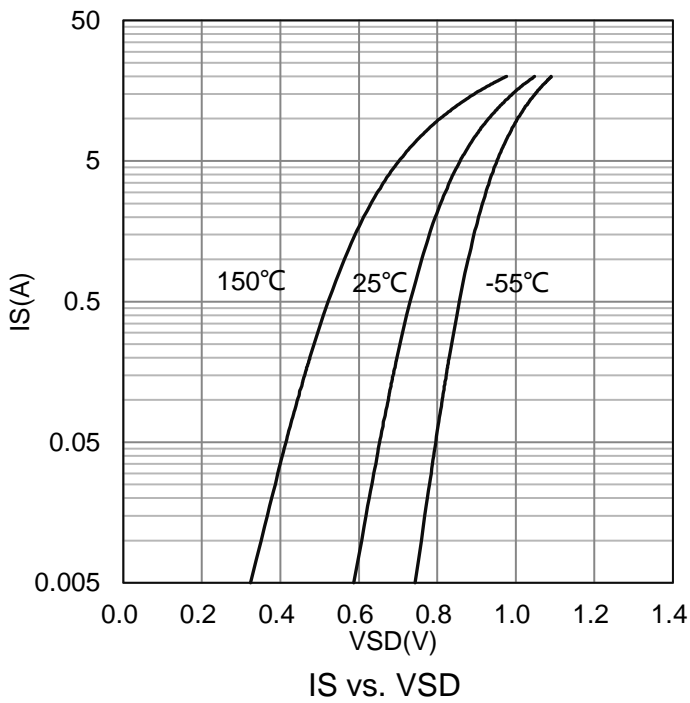
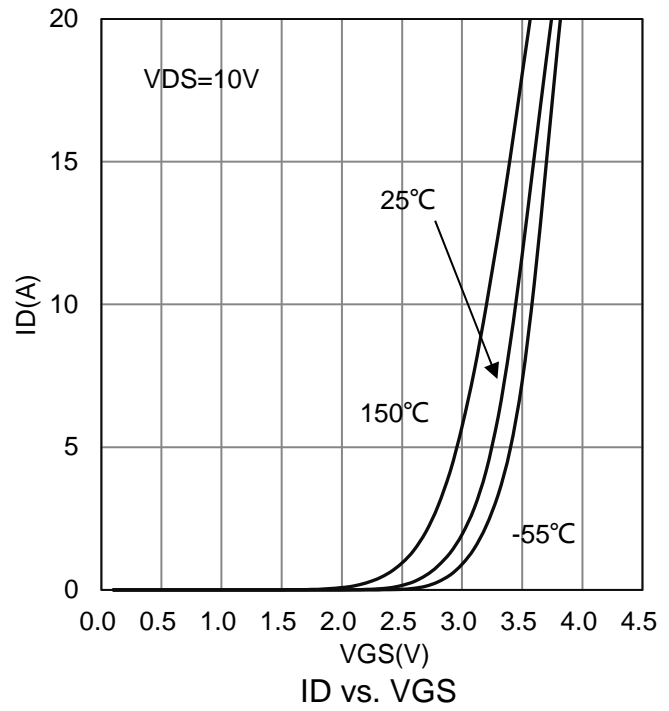
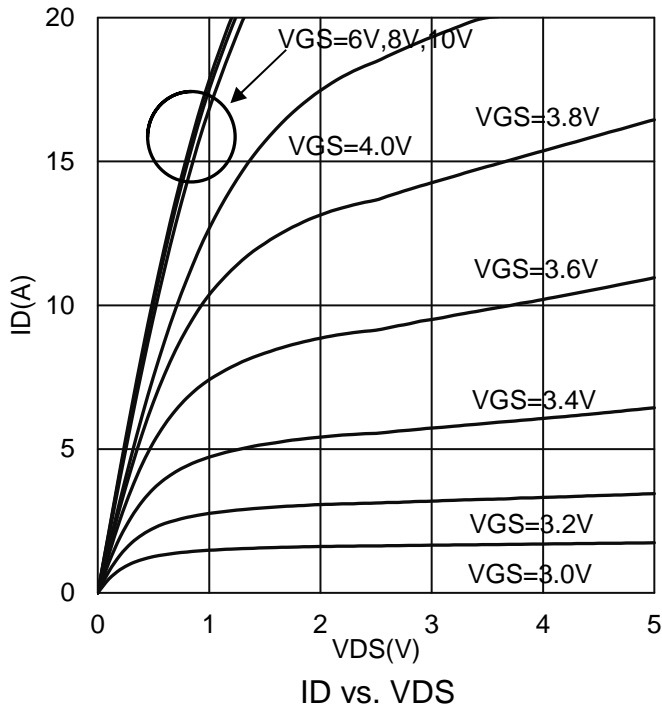

7. ELECTRICAL CHARACTERISTICS CURVES(Con.)

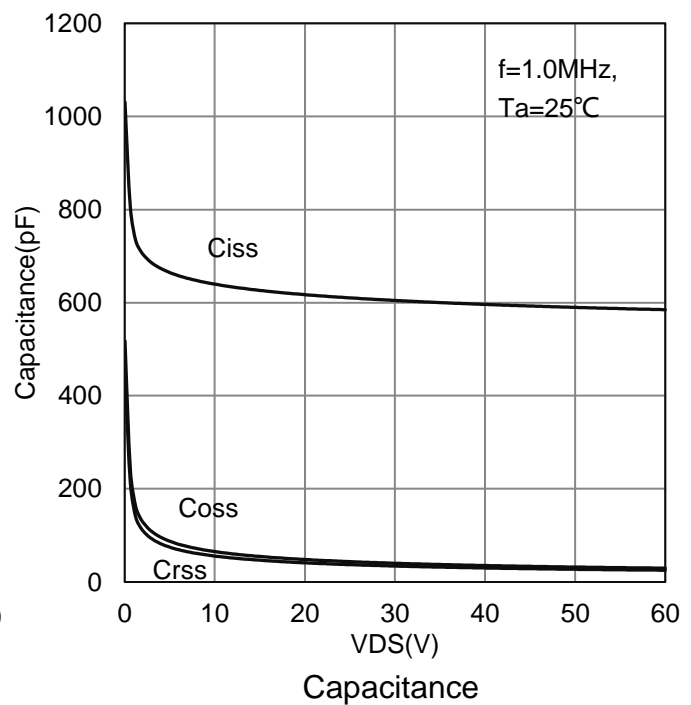
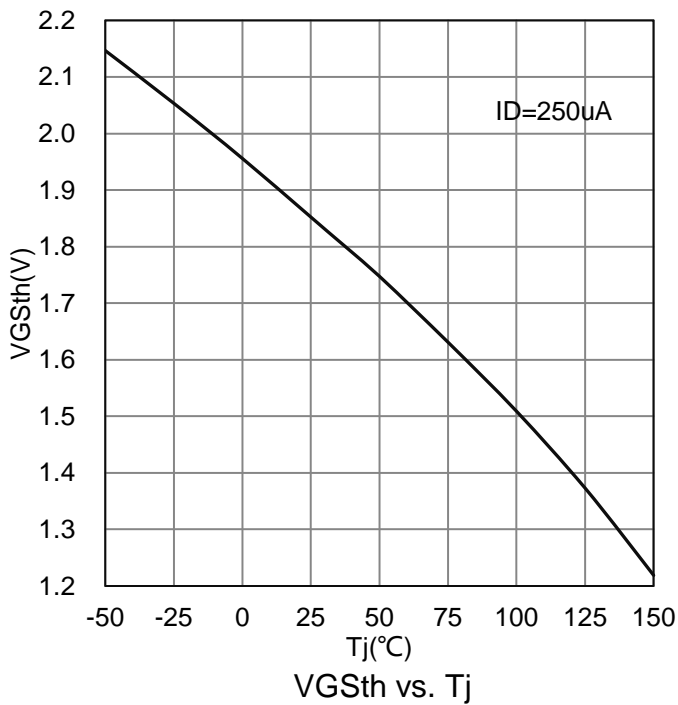
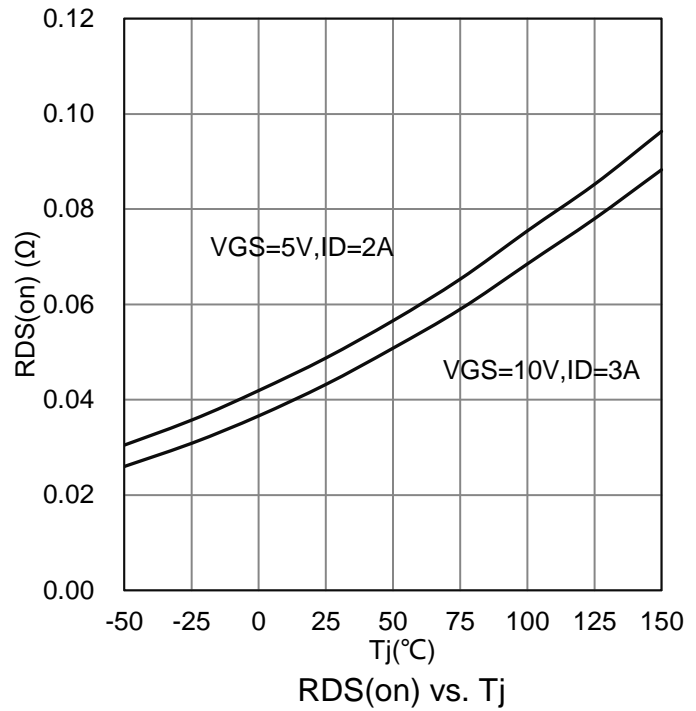
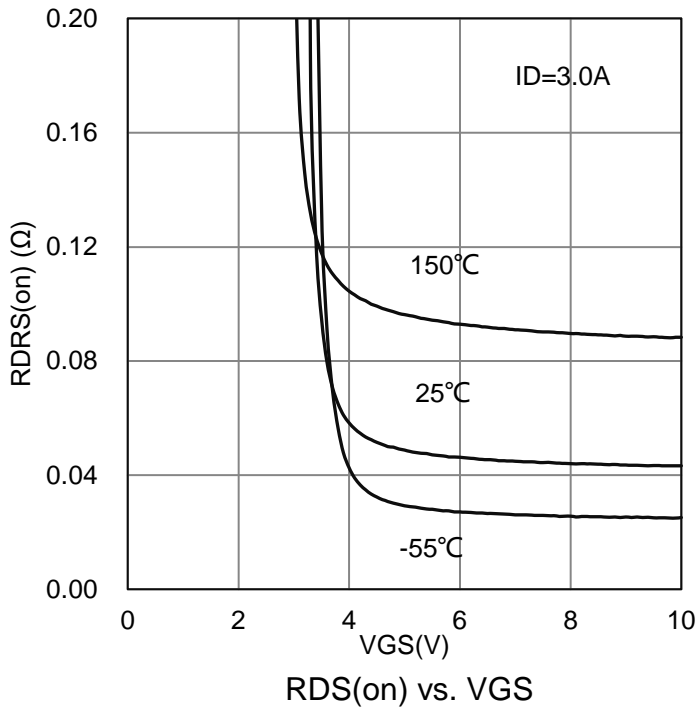

7. ELECTRICAL CHARACTERISTICS CURVES(Con.)

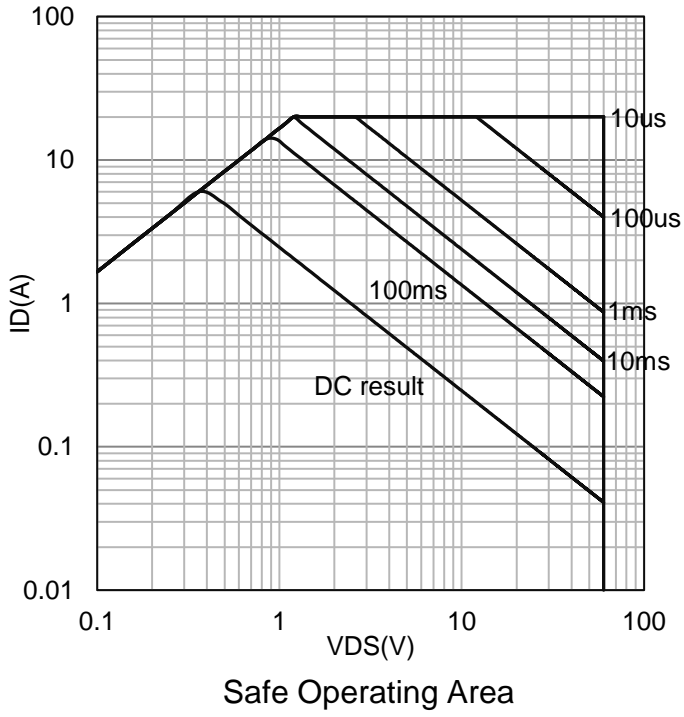

8. OUTLINE AND DIMENSIONS SOT223

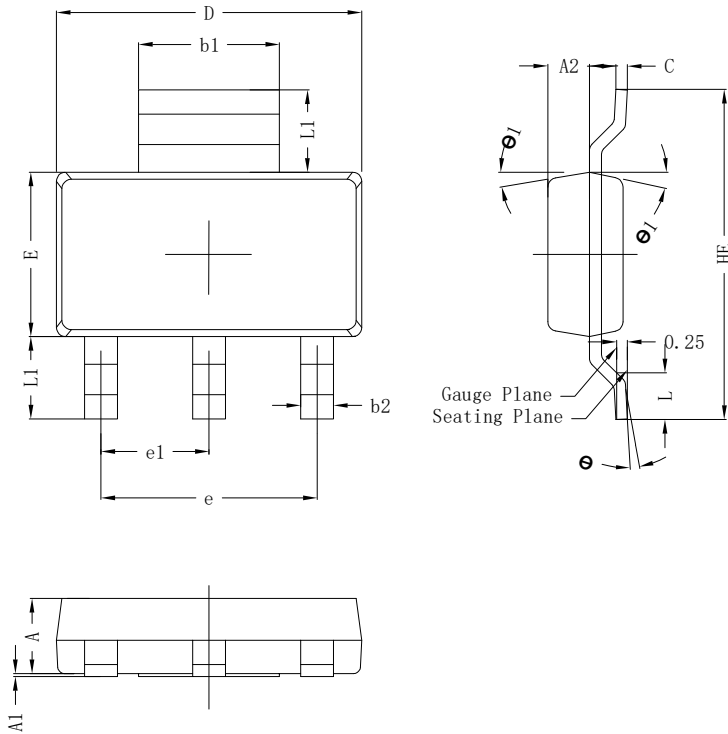

SOT223			
DIM	MIN	NOR	MAX
A	1.50	1.60	1.70
A1	0.00	0.05	0.10
A2	0.80	0.90	1.00
b1	2.90	3.02	3.10
b2	0.60	0.72	0.80
c	0.20	0.27	0.35
D	6.30	6.50	6.70
E	3.30	3.50	3.70
e	4.60BSC		
e1	2.30BSC		
HE	6.80	7.00	7.20
L	0.80	1.00	1.20
L1	1.75(REF)		
θ	0°~8°		
θ 1	8°	10°	12°
All Dimensions in mm			

GENERAL NOTES

1. Top package surface finish Ra0.4±0.2um
2. Bottom package surface finish Ra0.7±0.2um
3. Side package surface finish Ra0.4±0.2um
4. Protrusion or Gate Burrs shall not exceed 0.10mm per side.

9. SOLDERING FOOTPRINT

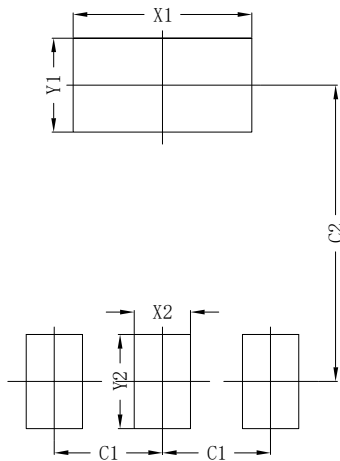

SOT223	
DIM	(mm)
X1	3.80
Y1	2.00
X2	1.20
Y2	2.00
C1	2.30
C2	6.30

DISCLAIMER

- Before you use our Products, you are requested to carefully read this document and fully understand its contents. LRC shall not be in any way responsible or liable for failure, malfunction or accident arising from the use of any LRC's Products against warning, caution or note contained in this document.
- All information contained in this document is current as of the issuing date and subject to change without any prior notice. Before purchasing or using LRC's Products, please confirm the latest information with a LRC sales representative.