

LP4306T1G

P-Channel 30-V (D-S) MOSFET

1. FEATURES

- Low RDS(on) trench technology.
- Low thermal impedance.
- Fast switching speed.
- We declare that the material of product are Halogen Free and compliance with RoHS requirements.

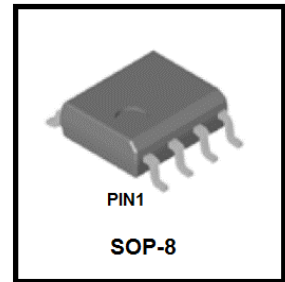

2. APPLICATION

- Load Switches
- DC/DC Conversion
- Motor Drives

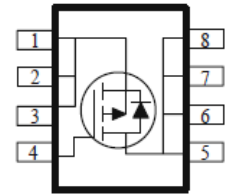

3. ORDERING INFORMATION

Device	Marking	Shipping
LP4306T1G	LP4306	4000/Tape&Reel

4. MAXIMUM RATINGS(Ta = 25°C unless otherwise stated)

Parameter	Symbol	Limits	Unit
Drain-to-Source Voltage	VDSS	-30	V
Gate-to-Source Voltage	VGS	± 20	V
Continuous Drain Current(Note 1)	ID	TA =25°C	-12
		TA =70°C	-9
Pulsed Drain Current (Note 2)	IDM	-48	A
Power Dissipation(Note 1)	PD	TA =25°C	1.6
		TA =70°C	1.2
Operating Junction Temperature	TJ	-55 ~+150	°C
Storage Temperature Range	Tstg	-55 ~+150	

5. THERMAL CHARACTERISTICS

Parameter	Symbol	Limits	Unit
Maximum Junction-to-Ambient(Note 1)	RθJA	65	°C/W

1.Surface Mounted on 1" x 1" FR4 Board.

2.Pulse width limited by maximum junction temperature.

6. ELECTRICAL CHARACTERISTICS

Characteristic	Symbol	Min.	Typ.	Max.	Unit	
Static						
Drain-Source Breakdown Voltage (VGS=0 , ID = -250 uA)	V(BR)DSS	-30	-	-	V	
Gate-Source Threshold Voltage (VDS = VGS , ID = -250 uA)	VGS(th)	-1	-1.3	-2	V	
Gate-Body Leakage (VDS = 0 V, VGS = ± 20 V)	IGSS	-	-	± 100	nA	
Zero Gate Voltage Drain Current (VDS = -30 V, VGS = 0 V)	IDSS	-	-	-1	μA	
Drain-Source On-Resistance(Note 3) (VGS = -10 V, ID = -9 A) (VGS = -4.5 V, ID = -9 A)	RDS(on)	-	8 11	13 17	mΩ	
Diode Forward Voltage(Note 3) (IS = -1A, VGS = 0 V)	VSD	-	-	-1.5	V	
Dynamic(Note 4)						
Total Gate Charge	(VDS = -15 V, VGS = -4.5 V, ID = -9 A)	Qg	-	20.5	-	nC
Gate-Source Charge		Qgs	-	6.5	-	
Gate-Drain Charge		Qgd	-	7	-	
Input Capacitance	(VDS = -15 V, VGS = 0 V, f = 1 MHz)	Ciss	-	2130	-	pF
Output Capacitance		Coss	-	247	-	
Reverse Transfer Capacitance		Crss	-	210	-	
Turn-On Delay Time	(VDD = - 15V , VGS = - 10V , RG =6Ω ,ID = - 1A)	td(on)	-	9	-	ns
Rise Time		tr	-	21.8	-	
Turn-Off Delay Time		td(off)	-	59.8	-	
Fall Time		tf	-	14.4	-	

3. Pulse test: PW ≤ 300μs duty cycle ≤ 2%.

4. Guaranteed by design, not subject to production testing.

7. ELECTRICAL CHARACTERISTICS CURVES

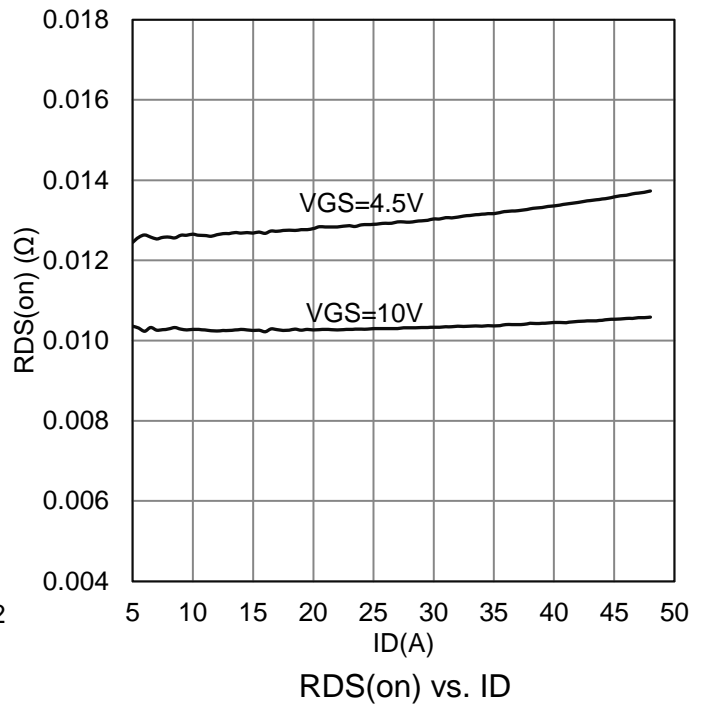
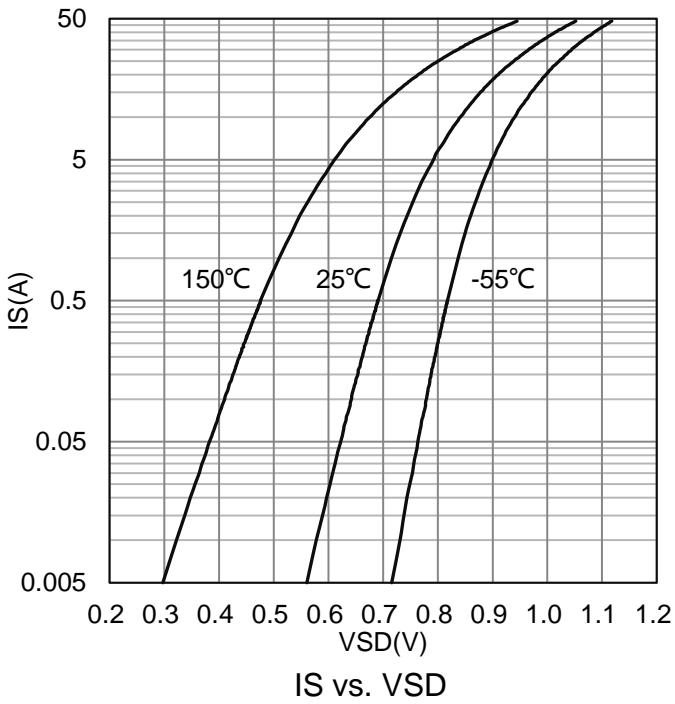
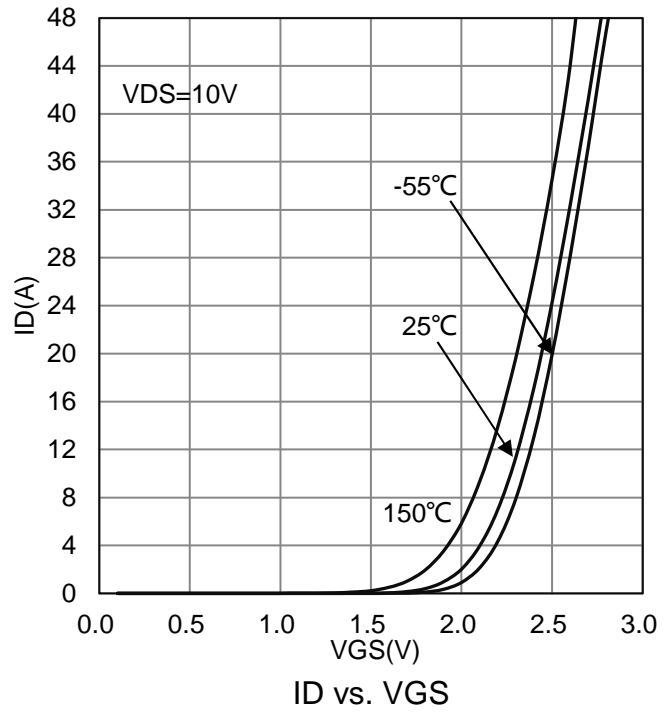
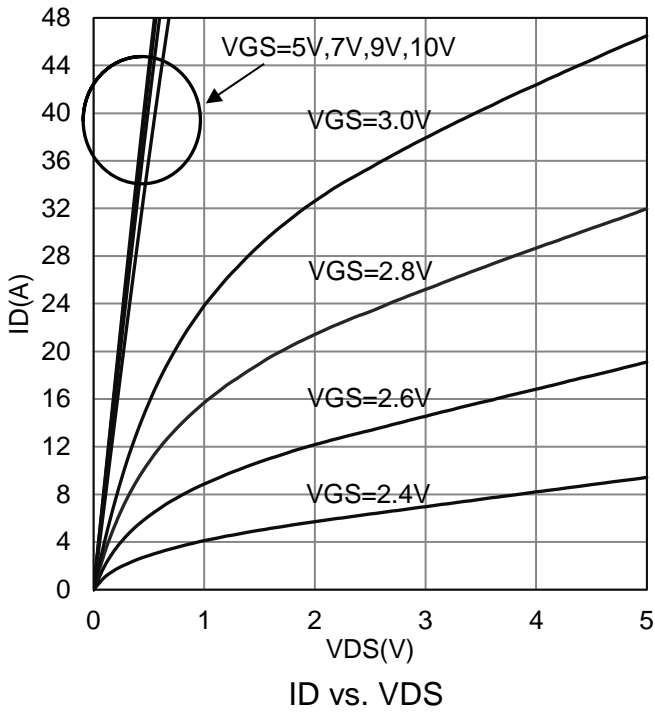

7. ELECTRICAL CHARACTERISTICS CURVES(Con.)

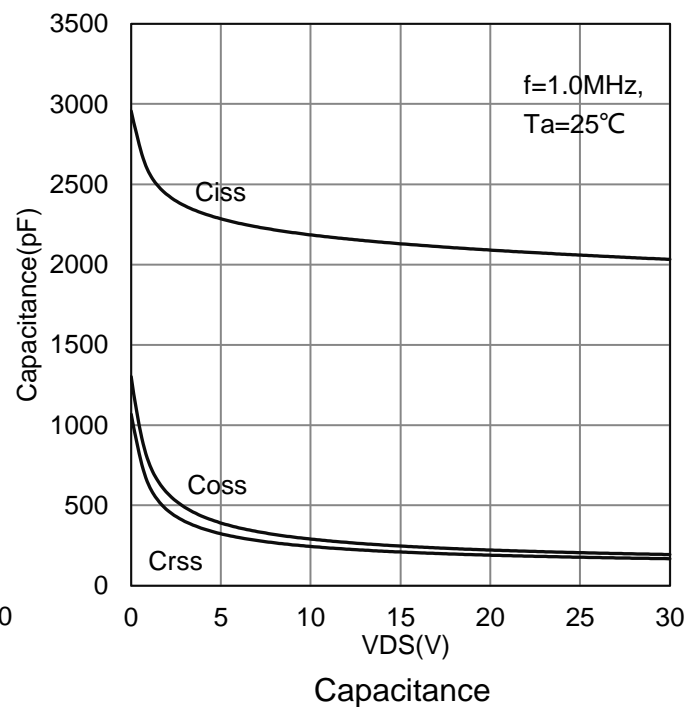
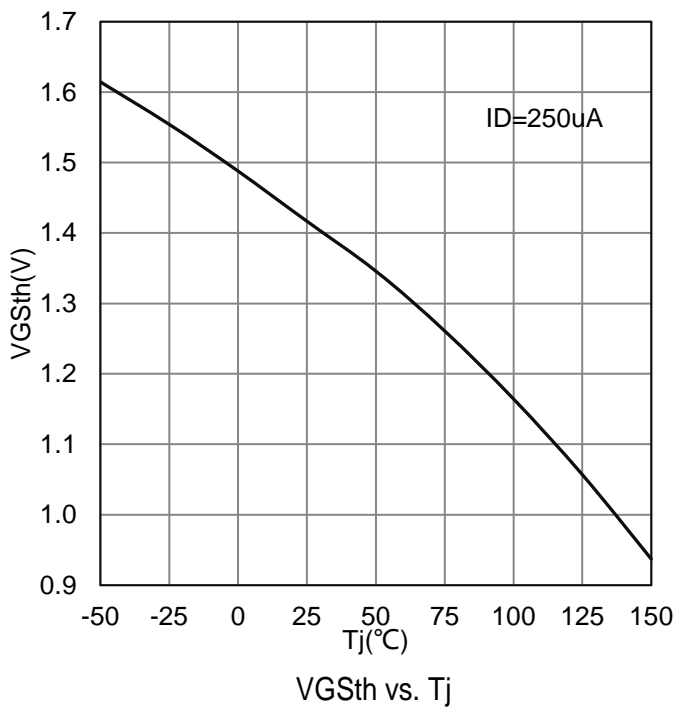
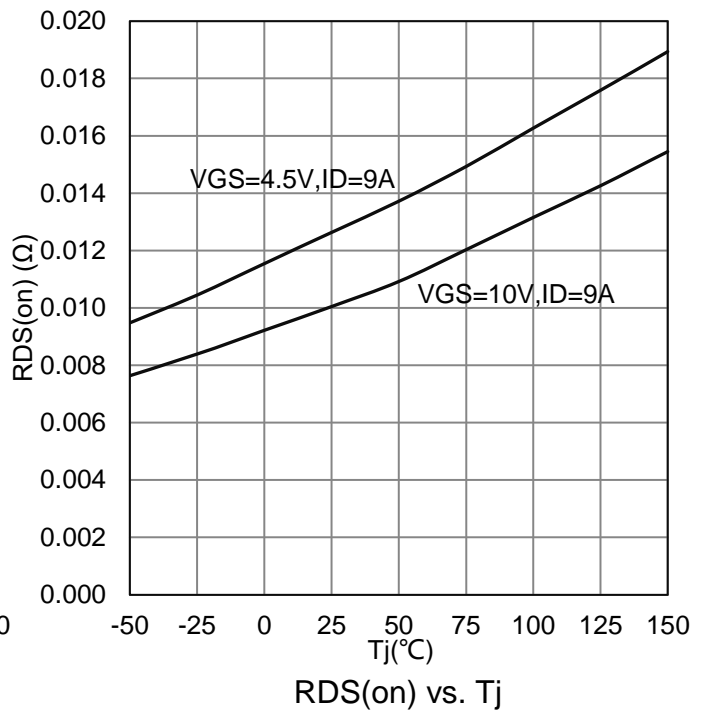
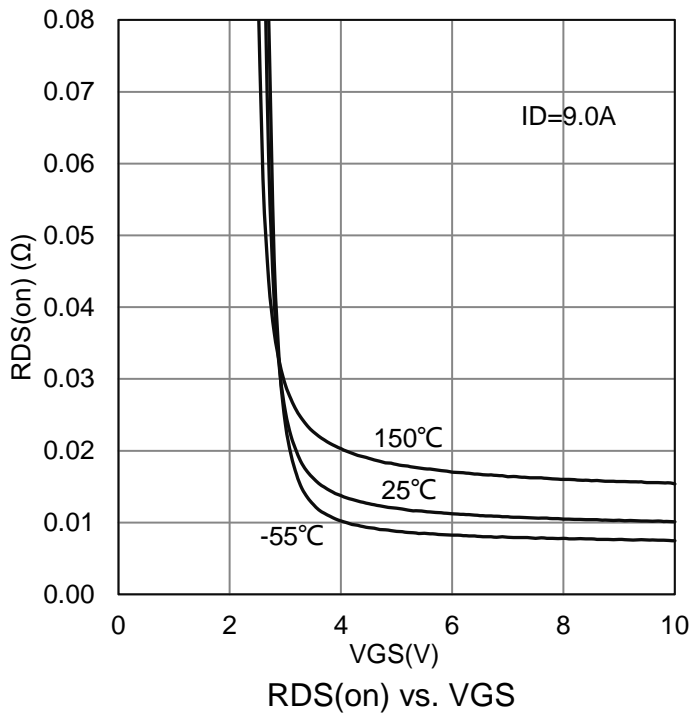

8. OUTLINE AND DIMENSIONS

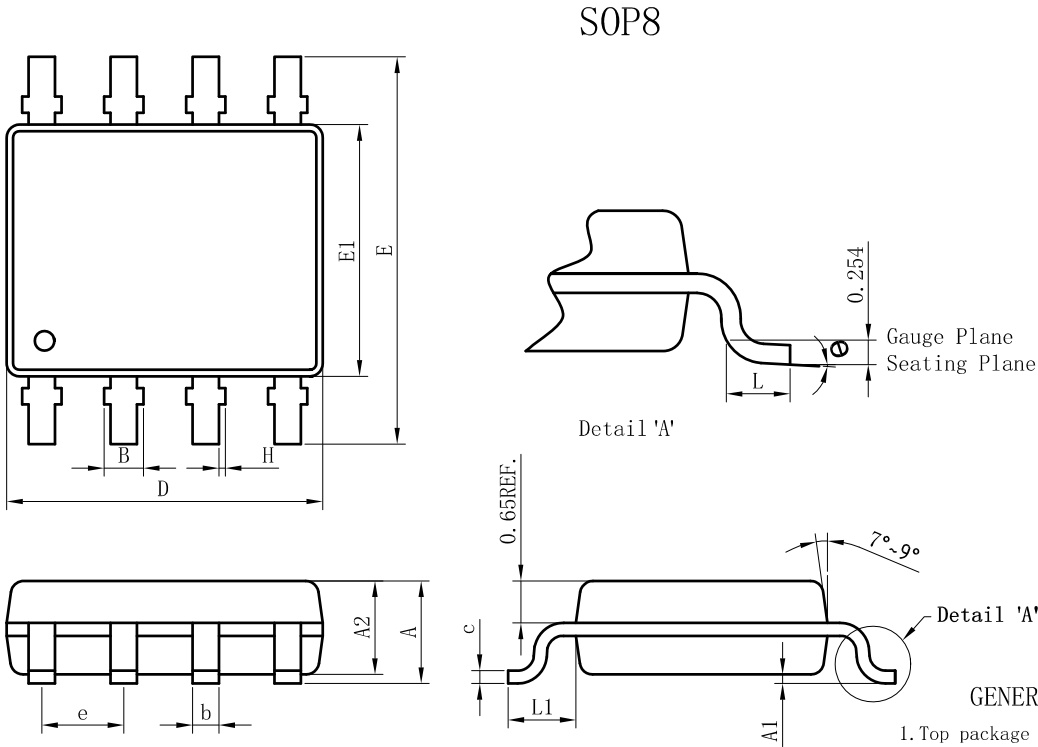

SOP8			
DIM	MIN	NOR	MAX
A	—	—	1.75
A1	0.10	0.15	0.20
A2	1.35	1.45	1.55
b	0.33	0.42	0.51
c	0.15	0.22	0.29
D	4.77	4.90	5.03
E	5.80	6.00	6.20
E1	3.80	3.90	4.00
e	1.27BSC		
L	0.46	0.66	0.86
L1	0.85	1.05	1.25
θ	0°	5°	8°
B	—	—	0.55
H	0	0.05	0.10
All Dimensions in mm			

GENERAL NOTES

1. Top package surface finish Ra0.4±0.2um
2. Bottom package surface finish Ra0.7±0.2um
3. Side package surface finish Ra0.4±0.2um
4. Package Body Sizes Exclude Mold Flash, Protrusion Or Gate Burrs. Mold Flash, Protrusion Or Gate Burrs Shall Not Exceed 0.10 mm Per Side.
5. Dimension "b" Does Not Include Dambar Protrusion.

9. SOLDERING FOOTPRINT

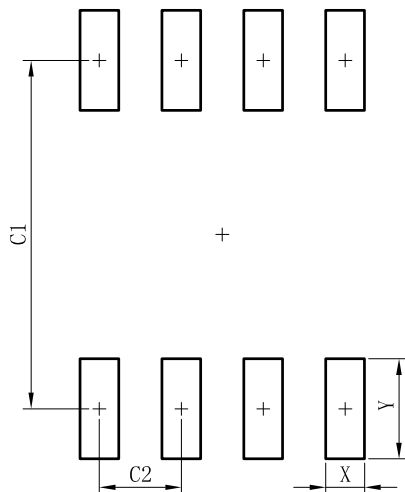

SOP8	
DIM	(mm)
X	0.60
Y	1.55
C1	5.40
C2	1.27

DISCLAIMER

- Before you use our Products, you are requested to carefully read this document and fully understand its contents. LRC shall not be in any way responsible or liable for failure, malfunction or accident arising from the use of any LRC's Products against warning, caution or note contained in this document.
- All information contained in this document is current as of the issuing date and subject to change without any prior notice. Before purchasing or using LRC's Products, please confirm the latest information with a LRC sales representative.